



**FLowsERVE**<sup>®</sup>

**VALTEK**<sup>®</sup>

*Mark Two Control Valves*

## Valtek Mark Two Body Assembly

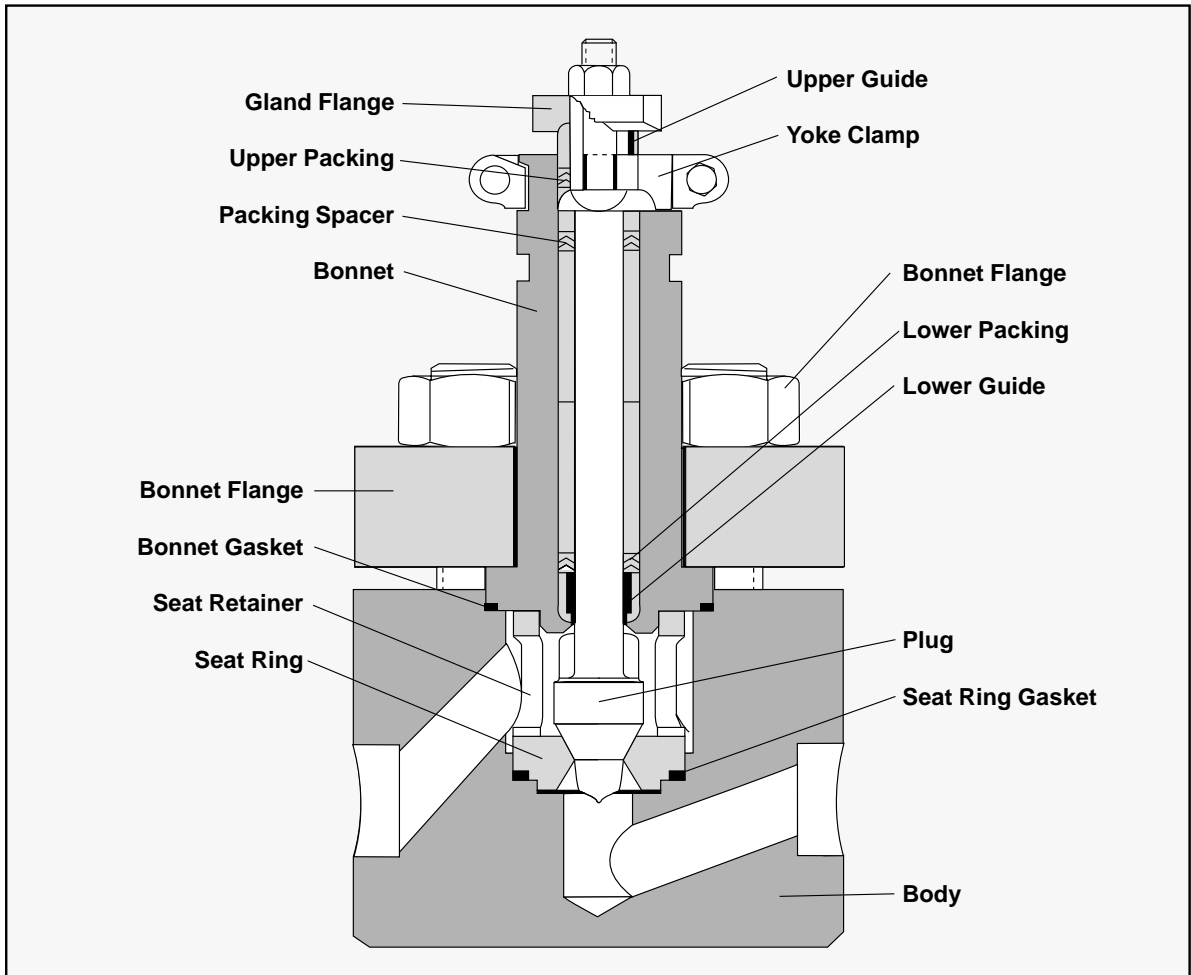

**Figure 1: Mark Two Body Assembly**

The Valtek® Mark Two™ control valve, available in many different configurations, is an extremely versatile automatic control valve. Fabricated from bar stock, it can be machined without foundry delays, even in high pressure classes or special alloys. This valve is generally available in sizes from 1/2 to 2-inch, but special configurations can be built to 6-inch.

The preferred body design is with socket-weld ends, but grayloc, butt-weld, flanged, and screwed ends are also available in ratings from 150 to 2500 psi / 10.3 to 172.4 bar, with special applications to 15,000 psi / 1034 bar.

Offset globe construction is generally less expensive than in-line construction.

Most common maintenance problems with comparable globe valves are associated with cage guiding — where close metal-to-metal contact between the cage and plug — often results in galling and binding. Conversely, the Mark Two is double-stem guided, completely avoiding contact between the plug and seat retainer. Top entry trim with a clamped-in seat also permits easy, quick maintenance.

## Valtek Mark Two

### Body Styles

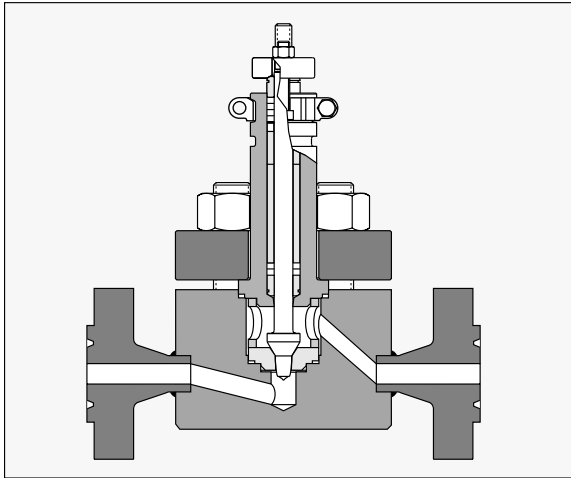

**Figure 2: In-line Globe**

This design, built to accommodate in-line piping systems, requires slightly more difficult and expensive angle-drilling of the bar stock. Complete valve trim (plug, seat ring, and retainer) is interchangeable regardless of body design (in-line, offset or angle). It is often interchangeable with Valtek Mark One control valves with identical pressure ratings.

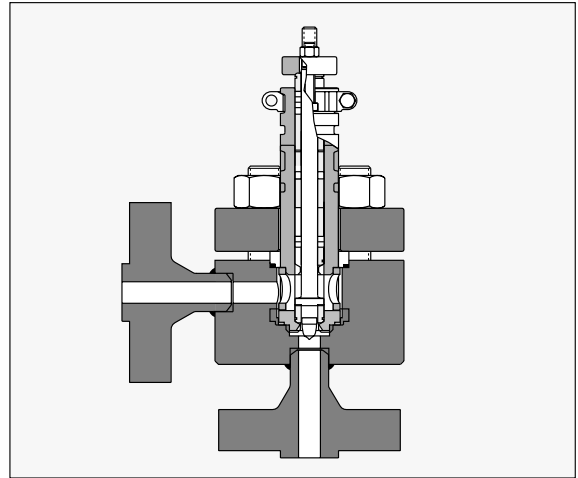

**Figure 3: Angle Body**

For interchangeability, only the body differs between globe and angle valves – all other parts are the same. This construction is available with outlets larger than inlet size for high pressure drop applications. The seat ring, when required, can be constructed to extend to the outlet flange, providing a venturi lining for the outlet passage.

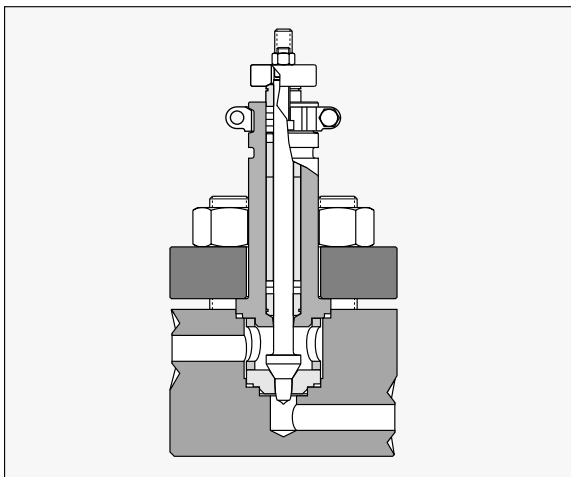

**Figure 4: Offset Globe**

When inlet and outlet piping can be offset, this design is the simplest, least expensive Valtek Mark Two control valve bar stock valve. Like the in-line and angle bodies, this design maintains the same interchangeability associated with Valtek Mark One control valves.

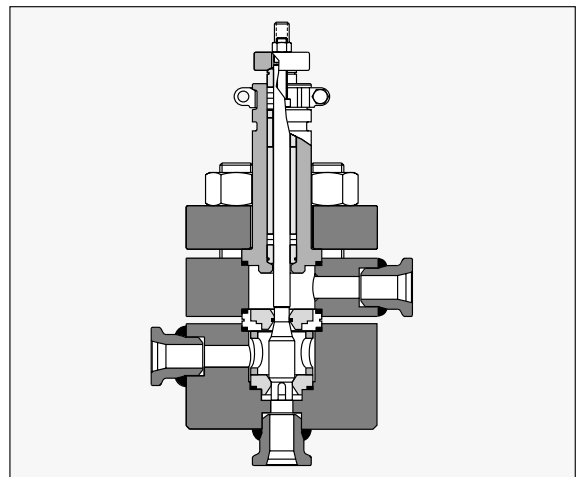

**Figure 5: Three-way Body**

One style is used for both combining and diverting services. For interchangeability, a standard Mark Two body converts to a three-way body with the addition of a three-way adapter, upper seat ring, three-way plug, two gaskets, and longer studs.

## Valtek Mark Two

### End Connections, Flanges, Bolting and Clamps

#### End Connections

The basic preferred end connection for Mark Two control valves is the socket weld because the socket can be machined into the bar stock body. Socket weld bodies are often available from stock. Other end connections can be fabricated from socket-weld body blanks. A wide variety of configurations and face-to-face dimensions are easily available by fabricating to the basic socket-weld construction.

#### Ratings

The Mark Two control valve design is basically for ratings of 900 lbs. / 1984 kg. and above. When fast delivery of special alloys or extensive material certifications and examinations is demanded by the application, pressure ratings less than 900 lbs. / 1984 kg. are available at a somewhat greater cost than standard cast bodies.

#### Bonnet Flange

Bonnet flanges are separable and are furnished in carbon steel. Stainless or other materials can be supplied where required by process atmospheres or extreme temperatures.

#### Bonnet Flange Bolting

Standard bolting is grade B7 studs and 2H nuts — suitable for  $-20^{\circ}$  to  $1000^{\circ}\text{F}$  /  $-29^{\circ}$  to  $538^{\circ}\text{C}$ . Studs and nuts in 316 stainless steel are suitable for  $-423^{\circ}$  to  $1500^{\circ}\text{F}$  /  $-253^{\circ}\text{C}$  to  $816^{\circ}\text{C}$ .

These temperature limits are for maximum pressures permitted by ANSI B16.5. Special alloy steels are available for higher pressures and temperatures.

#### Yoke Clamps

The actuator is usually attached to the Mark Two control valve body assembly with two precision cast, stainless steel yoke clamps, although in some cases the actuator is bolted directly to the bonnet. Each clamp has an inclined plane surface which, when bolted together, securely fastens the actuator yoke to the bonnet. Unlike conventional threaded clamps, Flowserve's clamp design permits easy removal even under extreme corrosive conditions.

Associated bolts and locknuts are supplied in plated carbon steel, although stainless steel is also available when required.



Figure 6: End Connections

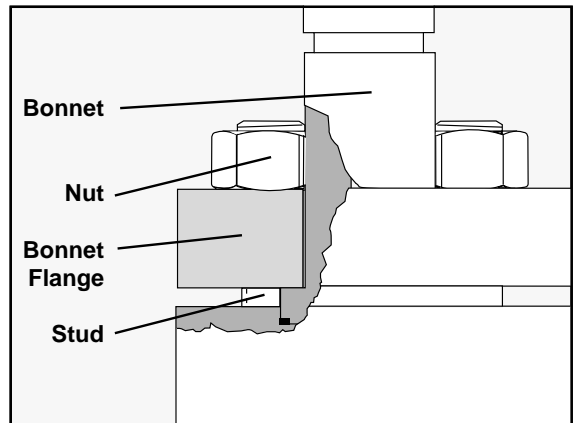

Figure 7: Bonnet Flange and Bolting

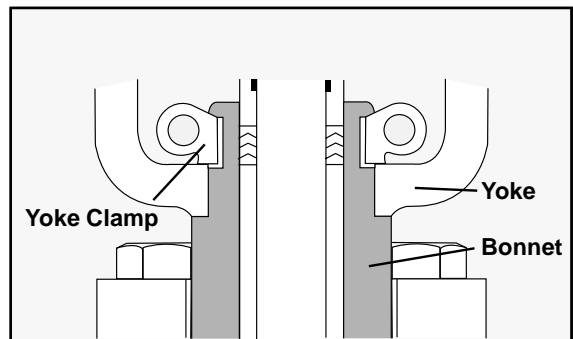
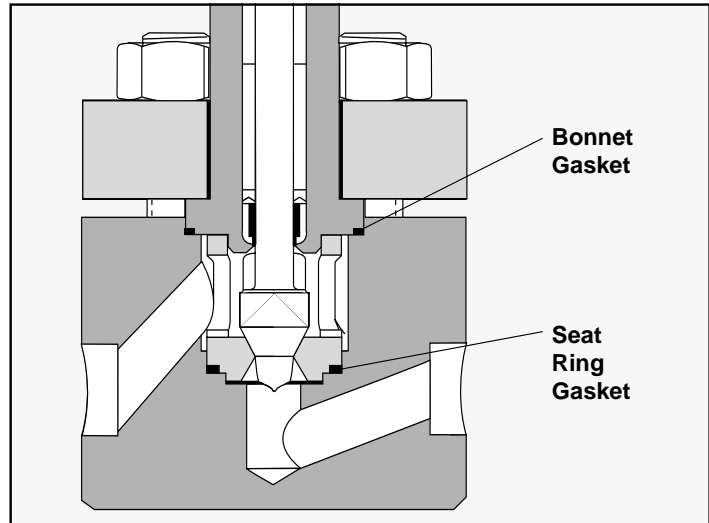

Figure 8: Yoke Clamp

## Valtek Mark Two Gaskets

The Mark Two control valve is designed with the bonnet and seat ring gaskets fully retained. Since the bonnet bottoms metal-to-metal in the body, the bonnet gasket compression is determined by the depth of the gasket step on the bonnet which is machined to provide the compression required by the gasket manufacturer.

When the bonnet is fully installed, force is transmitted through the seat retainer to secure the seat ring in position. The body, seat retainer and seat ring are all machined to close tolerances to provide the proper seat gasket compression. Unlike the bonnet, the seat ring does not bottom in the body, allowing this small clearance to compensate for manufacturing tolerances and thermal expansion.



**Figure 9: Seat Retainer Installation**

**Table I: Gasket Specifications**

	Body Material	Type	Gasket Material	Maximum Gasket Temp.° F / ° C	Minimum Gasket Temp.° F / ° C
<b>Standard Gaskets</b>	Carbon Steel	Spiral Wound	304 SS / asbestos	750 / 399	-20 / -29
	Carbon-Moly	Spiral Wound	316 SS / asbestos	1000 / 538	-20 / -29
	316 Stainless Steel	Flat	PTFE	450 / 232	-320 / -196
		Spiral Wound	316 SS / asbestos	1000 / 538	-20 / -29
	Other Alloys	Flat	PTFE	450 / 232	-320 / -196
<b>Alternate Gaskets</b>	As required	Flat	Asbestos	600 / 316	-20 / -29
		Flat	PTFE	450 / 232	-320* / -196
		Flat	PCTFE	350 / 177	-320* / -196
		Flat	Graphite**	1500 / 816	-320 / -196
		Spiral Wound	316 SS / Graphite	1500 / 816	-320 / -196
		Hollow O-ring	INCONEL X-750	1500 / 816	-20* / -196

\* Lower temperature on request.

\*\* Limited to 900°F / 482°C for oxidizing service.

## Valtek Mark Two

### Bonnet Types

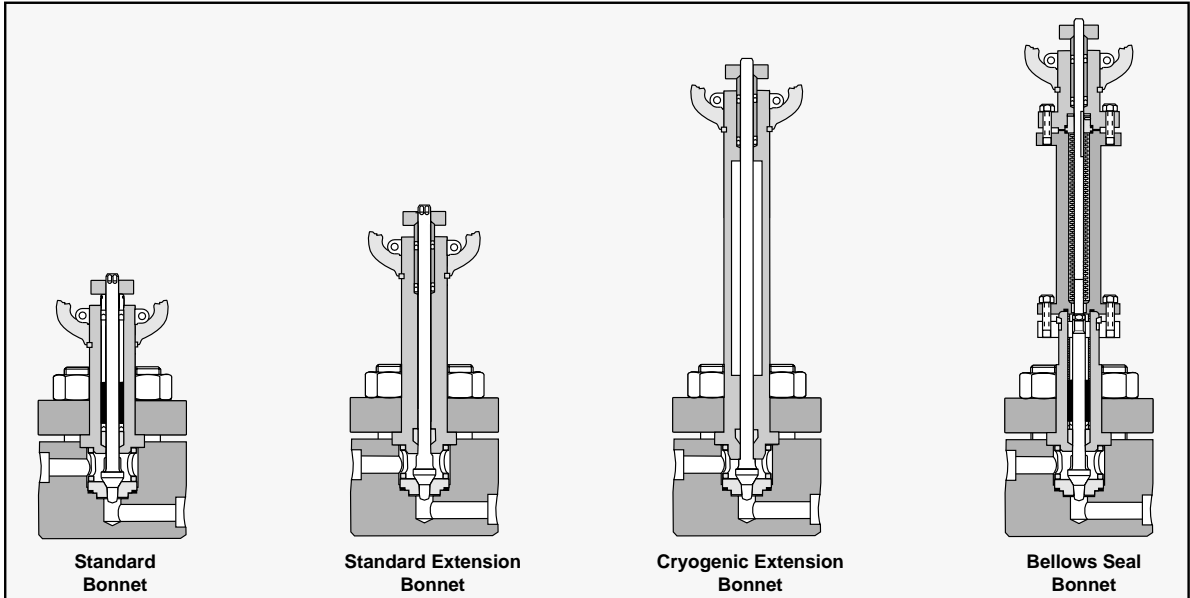

#### Standard Bonnet

The Mark Two bonnet is usually constructed out of the same material as the body and handles temperatures from  $-20^{\circ}$  to  $850^{\circ}\text{F}$  /  $-29^{\circ}\text{C}$  to  $454^{\circ}\text{C}$  (see Table 4 on page 9 of *Valtek Mark One Control Valves* for packing limitations); however, special packing must be considered at temperatures above  $450^{\circ}\text{F}$  /  $232^{\circ}\text{C}$ .

#### Extended Bonnet

The extended bonnet protects the packing from excessive heat or cold which may inhibit valve performance. It is constructed of carbon steel for temperatures from  $-20^{\circ}$  to  $800^{\circ}\text{F}$  /  $-29^{\circ}\text{C}$  to  $427^{\circ}\text{C}$  and of 304 or 316 stainless steel for temperatures from  $-320^{\circ}\text{F}$  to  $1500^{\circ}\text{F}$  /  $-196^{\circ}\text{C}$  to  $816^{\circ}\text{C}$ .

#### Cryogenic Extended Bonnet

The cryogenic extended bonnet permits stagnated, moderate temperature gas to form in the bonnet, which protects the packing from the service fluid. It is usually manufactured from 304 to 316 stainless steel and handles temperatures down to  $-423^{\circ}\text{F}$  /  $-253^{\circ}\text{C}$ . Standard construction consists of stainless steel bonnet flange and bolting.

#### Bellows Seal Extended Bonnet

The bellows seal extended bonnet can be used whenever service fluid leakage to atmosphere needs to be reduced to an absolute minimum.

The standard metal bellows seal is rated for operation at 150 psi / 10.3 bar at  $100^{\circ}\text{F}$  /  $38^{\circ}\text{C}$  or 90 psi / 6.2 bar at  $600^{\circ}\text{F}$  /  $316^{\circ}\text{C}$ ; special designs are available for pressures to 2900 psi / 200 bar and temperatures at  $1100^{\circ}\text{F}$  /  $593^{\circ}\text{C}$ .

The flexible metal bellows are usually constructed of 316L stainless steel. Bellows can also be furnished in alloys, such as Hastelloy and Inconel.

The bellows seal design allows for outside pressure to minimize bellows squirm, prolonging bellows life. Average full stroke cycle life that can be expected is shown in Table V.

The standard bellows, shown above, can be rated at other pressure, temperature or cycle life. Pressure ratings can be increased by reducing the calculated cycle life or by using special, short stroke plugs. Cycle life can be increased by reducing operating pressures or using short stroke plugs.

Since bellows seals are designed for specific service conditions and not to the valve's design class, it is necessary to include complete and accurate service conditions when specifying.

## Valtek Mark Two

### Trim Materials, Data

#### Trim Materials

Standard plug and seat ring material is 316 stainless steel except in the case of alloy bodies where trims are often furnished in the same material as the body.

Although it is difficult to assign specific limitations to the use of stainless steel due to insufficient information about the actual condition of the flowing stream, a wide variety of services are successfully handled by stainless steel trim parts. Nevertheless, a general rule is to consider hard trim for all choked flow conditions or for temperatures above 600°F / 316°C.

Valtek stocks Alloy 6 for many valve trim parts. This material offers a good combination of relative hardness and corrosion resistance. Special alloys such as Alloy 20, Hastelloy C and Monel, are also available.

**Table II: Plug Seat Areas and Strokes**

Seat Dia. (in. / cm.)	Seat Area (sq. in. / sq. cm.)	Stroke (in. / mm.)
0.125 / 0.317	0.012 / 0.0774	0.5 / 12.7
0.25 / 0.635	0.049 / 0.316	0.75 / 19.05
0.312 / 0.794	0.076 / 0.490	0.75 / 19.05
0.375 / 0.952	0.111 / 0.710	0.75 / 19.05
0.5 / 1.27	0.196 / 1.26	0.75 / 19.05
0.625 / 1.59	0.307 / 1.98	0.75 / 19.05
0.718 / 1.82	0.405 / 2.61	0.75 / 19.05
0.812 / 2.06	0.518 / 3.34	0.75 / 19.05
1 / 2.54	0.785 / 5.06	0.75 / 19.05
1.25 / 3.18	1.23 / 7.94	1 / 25.4
1.5 / 3.81	1.77 / 11.4	1 / 25.4
1.625 / 4.13	2.07 / 13.4	1.5 / 38.1
2 / 5.08	3.14 / 20.3	1.5 / 38.1
2.25 / 5.72	3.98 / 25.7	2 / 50.8
2.625 / 6.67	5.41 / 34.9	2 / 50.8
3 / 7.62	7.07 / 45.6	2 / 50.8
3.5 / 8.89	9.62 / 62.1	2.5 / 63.5

**Table III: Materials Characteristics**

Trim Material	Hardness Rockwell C	Corrosion* Resistance	Availability
316 Stainless Steel	8	Excellent	In Stock
Alloy 6	44	Good to Excellent	In Stock
416 Stainless Steel	40	Fair	Good
440 C. Stainless Steel	56	Fair	Fair
17-4 PH	40	Excellent	Good
Colmony	60	Fair to Good	Fair
Tungsten Carbide	72	Good on Bases Poor on Acids	Fair

\*General rule only. Check specific application.

**Table IV: Plug Stem Data-Unbalanced Trim**

Valve Size (inches)	Rating Class	Stem Dia. (in. / mm.)	Stem Thread	Stem Area (sq. in. / sq. mm.)	Actuator Size
1/2-1	150-2500	0.562 / 14.3	1/2-20	0.248 / 160	25
1 1/2-2	150-2500	0.875 / 22.2	3/4-16	0.601 / 388	50
3	150-600	1.125 / 28.6	1-12	0.994 / 641	50
3	900-1500	1.500 / 38.1	1 5/16-12	1.77 / 1140	100
3	2500	1.125 / 28.6	1-12	0.994 / 641	100
4	150-600	1.125 / 28.6	1-12	0.994 / 641	50
4	900-2500	1.500 / 38.1	1 5/16-12	1.77 / 1140	100

**Table V: Bellows Cycle Life**

Valve Size (inches)	Average Cycle Life
1/2, 3/4, 1	50,000
1 1/2, 2	30,000
3, 4 and 6 (Class 150)	8,000

## Valtek Mark Two

### Trim Data

**Table VI: Pressure Balance Trim**

Valve Size (inches)	Trim Number	Rating Class	Stem Area (in. <sup>2</sup> / mm <sup>2</sup> )	Off Balance Area (in. <sup>2</sup> / mm <sup>2</sup> )		Stroke (inch / mm)	Actuator Size
				To open valve with flow over plug	To close valve with flow under plug		
2	1.625	150-600	0.248 / 160	0.687 / 443	0.438 / 283	1 / 25.4	25
2	1.625	900-1500	0.248 / 160	0.508 / 328	0.257 / 166	1 / 25.4	25
2	1.25	2500	0.248 / 160	0.394 / 254	0.147 / 94.8	1 / 25.4	50
3	2.625	150-600	0.601 / 388	1.080 / 697	0.479 / 309	1.5 / 38.1	50
3	2.625	900-1500	0.601 / 388	1.080 / 697	0.479 / 309	2 / 50.8	100
3	2.00	2500	0.601 / 388	0.834 / 538	0.233 / 150	1.5 / 38.1	100
4	3.50	150-600	0.601 / 388	1.423 / 918	0.822 / 530	2 / 50.8	50
4	3.50	900-1500	0.994 / 641	1.423 / 918	0.430 / 277	2 / 50.8	100
4	2.625	2500	0.994 / 641	1.658 / 1070	0.666 / 430	2 / 50.8	100

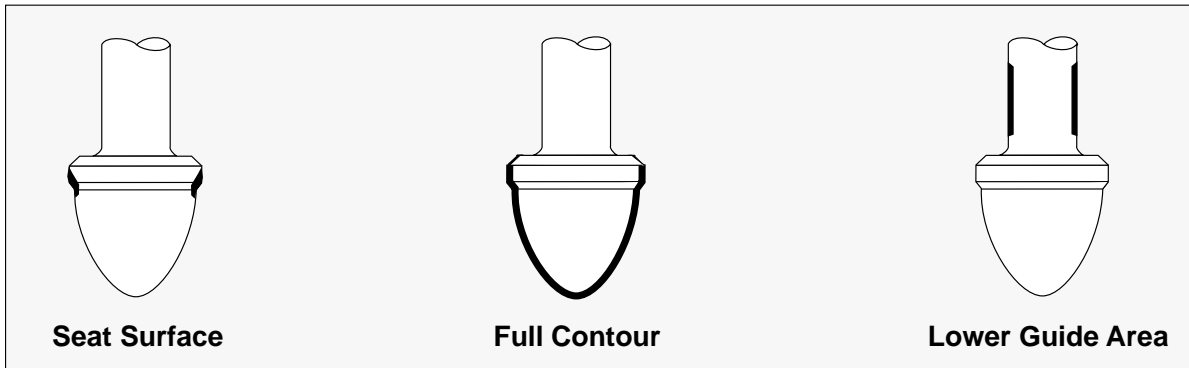

**Figure 10: Hard Facing Variations – Plug**

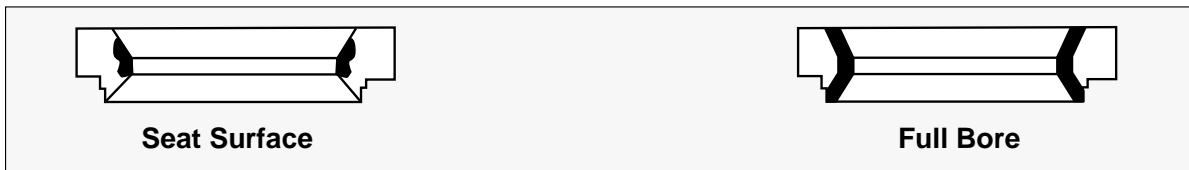

**Figure 11: Hard Facing Variations – Seat**

### C<sub>v</sub> Data

See Engineering Data 2 for flow coefficients (C<sub>v</sub>'s) according to trim characteristic, body rating, and flow direction.

## Valtek Mark Two

### Standard Materials of Construction Estimating Shipping Weight

#### Part Identification

Whenever possible, Flowserve numbers the part with ink or etching equipment. This identifies the part number and material used. Trim number, flow characteristic, part number and material are etched on the plug stem flat.

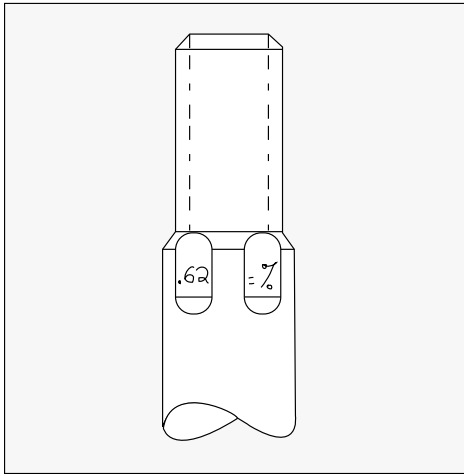

#### Name Plate

Valves are equipped with stainless steel name plates. An example is illustrated below.

Flowserve Corporation					
S/N	MARK	SIZE			
CLASS	T/N	Cv	CHAR		
<input type="radio"/> AIR TO	SIGNAL		<input type="radio"/>		
<input type="radio"/> BODY	TRIM				
TAG					
P.O.					

**Table VIII: Standard Materials of Construction**

Part	Material
Body & Bonnet	Steel 304, 304L, 316, 316L, 347 Stainless Steel, Bronze, Alloy 20, Hastelloy 'B' and 'C', Nickel, Monel, Inconel, Chrome Moly, Titanium
Bonnet Flanges	Steel
Retaining Rings	Zinc Plated Steel
Plug	316 Stainless Steel or same as Alloy body
Retainer	316 Stainless Steel or same as Alloy body
Seat Ring	316 Stainless Steel or same as Alloy body
Guides	Bronze, graphite lined St.St., Alloy 6
Packing	PTFE V-Ring, PTFE Asbestos, Graphite Asbestos
Packing Spacer	316 Stainless Steel or same as Alloy body
Seat Ring and Bonnet Gaskets	Stainless Steel and Asbestos spiral wound, PTFE
Body Bolts	Zinc Plated Steel B7-2H
Gland Flange	Precision Cast Stainless Steel
Gland Flange Nuts & Bolts	Zinc Plated Steel
Yoke Clamp Bolts	Zinc Plated Steel
Yoke Clamp	Precision Cast Stainless Steel

**Table VII: Estimating Shipping Weights**

Inline, Offset & Angle Valves with Cylinder Actuators and Positioners

Size (Inches)	Weight (lbs. / kg.)				Add for Standard Ext. Bonnet
	Class 150-600	Class 900	Class 1500	Class 2500	
1/2-3/4	85 / 39	90 / 41	90 / 41	100 / 45	5 / 2.3
1	90 / 41	95 / 44	95 / 43	110 / 50	5 / 2.3
1 1/2	155 / 70	190 / 86	190 / 86	195 / 89	10 / 4.5
2	170 / 77	205 / 93	205 / 93	210 / 95	10 / 4.5
3	250 / 114	325 / 148	325 / 148	350 / 159	15 / 6.8
4	400 / 182	500 / 227	500 / 227	550 / 250	15 / 6.8

\*Weights for socket weld end bodies

Add for oversize cylinder actuators.

Original Size	Oversize	Add
25	50	30 lbs. / 13.6 kg.
50	100	90 lbs. / 40.9 kg.
100	200	125 lbs. / 56.8 kg.

## Valtek Mark Two Offset Dimensions

End Types	Rating ANSI	1/2-inch				3/4-inch				1-inch			
		A	B	C	D	A	B	C	D	A	B	C	D
<b>Socket Weld</b> 	150	4.50	2.94	1.18	1.69	4.50	2.94	1.18	1.69	4.50	2.94	1.18	1.69
	300	"	"	"	"	"	"	"	"	"	"	"	"
	600	"	"	"	"	"	"	"	"	"	"	"	"
	900-1500	5.50	4.62	.75	1.75	5.50	4.62	.81	1.81	5.50	4.62	1.12	2.00
	2500	6.50	5.50	1.00	2.00	6.50	5.50	1.00	2.00	6.50	5.62	1.12	2.12
<b>Grayloc</b> 	150	7.25	2.94	1.18	1.69	7.00	2.94	1.18	1.69	6.88	2.94	1.18	1.69
	300	"	"	"	"	"	"	"	"	"	"	"	"
	600	"	"	"	"	"	"	"	"	"	"	"	"
	900-1500	8.25	4.62	.75	1.75	7.88	4.62	.81	1.81	7.88	4.62	1.12	2.00
	2500	9.25	5.50	1.00	2.00	8.88	5.50	1.00	2.00	8.88	5.62	1.12	2.12
<b>Butt Weld</b> 	150	4.38	2.94	1.18	1.69	4.38	2.94	1.18	1.69	4.38	2.94	1.18	1.69
	300	"	"	"	"	"	"	"	"	"	"	"	"
	600	"	"	"	"	"	"	"	"	"	"	"	"
	900-1500	5.38	4.62	1.12	1.75	5.38	4.62	.81	1.81	5.38	4.62	1.12	2.00
	2500	6.38	5.50	1.00	2.00	6.38	5.50	1.00	2.00	6.38	5.62	1.12	2.12
<b>Raised Face</b> 	150	7.50	2.94	1.18	1.69	7.50	2.94	1.18	1.69	7.75	2.94	1.18	1.69
	300	7.88	"	"	"	7.88	"	"	"	8.25	2.94	1.18	1.69
	600	8.38	"	"	"	8.38	"	"	"	8.75	"	"	"
	900-1500	10.00	4.62	.75	1.75	10.38	4.62	.81	1.81	10.62	4.62	1.12	2.00
	2500	12.00	5.50	1.00	2.00	12.12	5.50	1.00	2.00	12.88	5.62	1.12	2.12
<b>RTJ</b> 	150									8.12	2.94	1.18	1.69
	300	8.19	2.94	1.18	1.69	8.25	2.94	1.18	1.69	8.62	"	"	"
	600	8.38	"	"	"	8.38	"	"	"	8.75	"	"	"
	900-1500	10.00	4.62	.75	1.75	10.38	4.62	.81	1.81	10.62	4.62	1.12	2.00
	2500	12.00	5.50	1.00	2.00	12.12	5.50	1.00	2.00	12.88	5.62	1.12	2.12
<b>NPT</b> 	150	4.50	2.94	1.18	1.69	4.50	2.94	1.18	1.69	4.50	2.94	1.18	1.69
	300	"	"	"	"	"	"	"	"	"	"	"	"
	600	"	"	"	"	"	"	"	"	"	"	"	"
	900-1500	5.50	4.62	.75	1.75	5.50	4.62	.81	1.81	5.50	4.62	1.12	2.12
	2500	6.50	5.50	1.00	2.00	6.50	5.50	1.00	2.00	6.50	5.62	1.12	"
<b>Bonnet Ext.</b> Add this dimension to 'B' (above)	150 - 600		4.5				4.5				4.5		
	900-1500		4.5				4.5				4.5		
	2500		4.5				4.5				4.5		
<b>Bellows Seal</b> Add this dimension to 'B' (above)	150-600		12.66				12.66				12.66		
	900-1500		12.66				12.66				12.66		
<b>Clearance</b> Above Actuator Required for Disassemble	150-600		2.50				2.50				2.50		
	900-1500		3.50				3.50				3.50		
	2500		3.50				3.50				3.50		

## Valtek Mark Two Offset Dimensions

End Types	Rating ANSI	1½-inch				2-inch			
		A	B	C	D	A	B	C	D
<b>Socket Weld</b> 	150	6.00	3.50	1.62	2.88	6.00	3.50	2.00	2.88
	300	"	"	"	"	"	"	"	"
	600	"	"	"	"	"	"	"	"
	900-1500	7.50	5.88	1.50	2.62	7.50	6.09	1.75	2.88
	2500	8.00	6.91	1.56	2.81	8.00	7.22	1.94	2.75
<b>Grayloc</b> 	150	9.50	3.50	1.62	2.88	9.75	3.50	1.75	2.88
	300	"	"	"	"	"	"	"	"
	600	"	"	"	"	"	"	"	"
	900-1500	11.00	5.88	1.50	2.62	11.38	6.09	1.75	2.88
	2500	11.50	6.91	1.56	2.81	11.88	7.22	1.94	2.75
<b>Butt Weld</b> 	150	5.62	3.50	1.62	2.88	5.50	3.50	2.00	2.88
	300	"	"	"	"	"	"	"	"
	600	"	"	"	"	"	"	"	"
	900-1500	7.25	5.88	1.50	2.62	7.12	6.09	1.75	2.88
	2500	7.75	6.91	1.56	2.81	7.62	7.22	1.94	2.75
<b>Raised Face</b> 	150	9.62	3.50	1.62	2.88	9.25	3.50	2.00	2.88
	300	10.12	"	"	"	9.75	"	"	"
	600	10.75	"	"	"	10.50	"	"	"
	900-1500	13.25	5.88	1.50	2.62	14.38	6.09	1.75	2.88
	2500	16.00	6.91	1.56	2.81	16.88	7.22	1.94	2.75
<b>RTJ</b> 	150	10.00	3.50	1.62	2.88	9.62	3.50	2.00	2.88
	300	10.50	"	"	"	10.25	"	"	"
	600	10.75	"	"	"	10.62	"	"	"
	900-1500	13.25	5.88	1.50	2.62	14.50	6.09	"	2.88
	2500	16.12	6.91	1.56	2.81	17.00	7.16	1.94	2.75
<b>NPT</b> 	150	6.00	3.50	1.62	2.88	6.00	3.50	2.00	2.88
	300	"	"	"	"	"	"	"	"
	600	"	"	"	"	"	"	"	"
	900-1500	7.50	5.88	1.50	2.62	7.50	6.09	1.75	2.88
	2500	8.00	6.91	1.56	2.81	8.00	7.22	1.94	2.75
<b>Bonnet Ext.</b> Add this dimension to 'B' (above)	150-600	4.5				4.5			
	900-1500	5.5				5.5			
	2500	5.5				5.5			
<b>Bellows Seal</b> Add this dimension to 'B' (above)	150-600	16.0				16.0			
	900-1500	16.0				16.0			
<b>Clearance</b> Above Actuator Required for Disassemble	150-600	4.25				4.75			
	900-1500	4.50				4.50			
	2500	4.50				4.50			

## Valtek Mark Two In-line Dimensions

End Types	Rating ANSI	1/2-inch			3/4-inch			1-inch			1 1/2-inch			2-inch		
		A	B	C	A	B	C	A	B	C	A	B	C	A	B	C
<b>Socket Weld</b> 	150	5.50	4.06	1.19	5.50	4.25	1.44	5.50	4.25	1.44	8.00	5.38	2.50	8.00	5.50	3.12
	300	"	"	"	"	"	"	"	"	"	"	"	"	"	"	"
	600	"	"	"	"	"	"	"	"	"	"	"	"	"	"	"
	900-1500	"	6.12	1.25	"	6.12	1.38	"	6.06	1.56	"	"	"	"	"	"
	2500	6.50	7.25	1.38	6.50	7.12	"	6.50	7.44	1.44	8.00	8.94	2.47	8.00	8.65	3.75
<b>Grayloc</b> 	150	8.25	4.06	1.19	8.00	4.25	1.44	7.88	4.25	1.44	11.50	5.38	2.50	11.88	5.50	3.12
	300	"	"	"	"	"	"	"	"	"	"	"	"	"	"	"
	600	"	"	"	"	"	"	"	"	"	"	"	"	"	"	"
	900-1500	"	6.12	1.25	7.88	6.12	1.38	"	6.06	1.56	*	*	*	*	*	*
	2500	9.25	7.25	1.38	8.88	7.12	"	8.88	7.44	1.44	11.50	8.94	2.47	11.88	8.65	3.75
<b>Butt Weld</b> 	150	8.25	4.06	1.19	8.00	4.25	1.44	7.88	4.25	1.44	11.50	5.38	2.50	11.88	5.50	3.12
	300	"	"	"	"	"	"	"	"	"	"	"	"	"	"	"
	600	"	"	"	"	"	"	"	"	"	"	"	"	"	"	"
	900-1500	"	6.12	1.25	7.88	6.12	1.38	"	6.06	1.56	*	*	*	*	*	*
	2500	9.25	7.25	1.38	8.88	7.12	"	8.88	7.44	1.44	11.50	8.94	2.47	11.88	8.65	3.75
<b>Raised Face</b> 	150	8.50	4.06	1.19	8.62	4.25	1.44	8.75	4.25	"	11.62	5.38	2.50	11.38	5.50	3.12
	300	8.88	"	"	9.00	"	"	9.25	"	"	12.12	"	"	11.88	"	"
	600	9.37	"	"	9.50	"	"	9.75	"	"	12.75	"	"	12.62	"	"
	900-1500	10.00	6.12	1.25	10.38	6.12	1.38	10.62	6.06	1.56	*	*	*	*	*	*
	2500	12.00	7.25	1.38	12.12	7.12	"	12.88	7.44	1.44	16.00	8.94	2.47	16.88	9.65	3.75
<b>RTJ</b> 	150							9.12	4.25	1.44	12.00	5.38	2.50	11.75	5.50	3.12
	300	9.19	4.06	1.19	9.38	4.25	1.44	9.62	"	"	12.50	"	"	12.38	"	"
	600	9.31	"	"	9.50	"	"	9.75	"	"	12.75	"	"	12.75	"	"
	900-1500	10.00	6.12	1.25	10.38	6.12	1.38	10.62	6.06	1.56	*	*	*	*	*	*
	2500	12.00	7.25	1.38	12.12	7.12	"	12.88	7.44	1.44	16.12	8.94	2.47	17.00	8.65	3.75
<b>NPT</b> 	150	9.50	4.06	1.19	8.00	4.25	1.44	7.88	4.25	1.44	11.50	5.38	2.50	11.88	5.50	3.12
	300	"	"	"	"	"	"	"	"	"	"	"	"	"	"	"
	600	"	"	"	"	"	"	"	"	"	"	"	"	"	"	"
	900-1500	"	6.12	1.25	7.88	6.12	1.38	"	6.06	1.56	*	*	*	*	*	*
	2500	9.25	7.25	1.38	8.88	7.12	"	8.88	7.44	1.44	11.50	8.94	2.47	11.88	8.65	3.75
<b>Bonnet Ext.</b> Add dimension to 'B' (Above)	150-600	4.5			4.5			4.5			4.5			4.5		
	900-1500	4.5			4.5			4.5			5.5			5.5		
	2500	4.5			4.5			4.5			5.5			5.5		
<b>Bellows Seal</b> Add this dimension to 'B' (above)	150-600	12.66			12.66			12.66			16.0			16.0		
<b>Clearance</b> Above Actuator Required for Disassemble	150-600	2.50			2.50			2.50			4.25			4.75		
	900-1500	3.50			3.50			3.50			4.50			4.50		
	2500	3.50			3.50			3.50			4.50			4.50		

\*Available in Class 2500 body only

# Valtek Mark Two Angle Dimensions

End Types	Rating ANSI	1/2-inch			3/4-inch			1-inch			1 1/2-inch			2-inch		
		A	B	C	A	B	C	A	B	C	A	B	C	A	B	C
<b>Socket Weld</b> 	150	2.25	2.94	2.38	2.25	2.94	2.38	2.25	2.94	2.38	3.00	3.50	3.62	3.00	3.50	3.81
	300	"	"	"	"	"	"	"	"	"	"	"	"	"	"	"
	600	"	"	"	"	"	"	"	"	"	"	"	"	"	"	"
	900-1500	2.75	4.62	"	2.75	4.62	2.62	2.75	4.62	2.62	3.75	5.85	3.25	3.75	6.09	3.56
	2500	3.25	5.50	2.50	3.25	5.50	2.50	3.25	5.62	2.50	4.00	6.91	"	4.00	7.16	3.63
<b>Grayloc</b> 	150	3.62	2.94	3.75	3.50	2.94	3.62	3.44	2.94	3.62	4.75	3.50	5.50	4.88	3.50	5.93
	300	"	"	"	"	"	"	"	"	"	"	"	"	"	"	"
	600	"	"	"	"	"	"	"	"	"	"	"	"	"	"	"
	900-1500	4.12	4.62	3.75	3.94	4.67	3.88	3.94	4.62	3.88	5.50	5.85	5.12	5.69	6.09	5.69
	2500	4.62	5.50	3.88	4.44	5.50	3.75	4.44	5.62	3.75	5.75	6.91	5.12	5.94	7.16	5.75
<b>Butt Weld</b> 	150	2.19	2.94	2.38	2.19	2.94	2.38	2.19	2.94	2.38	2.81	3.50	3.62	2.75	3.50	3.81
	300	"	"	"	"	"	"	"	"	"	"	"	"	"	"	"
	600	"	"	"	"	"	"	"	"	"	"	"	"	"	"	"
	900-1500	2.68	4.62	"	2.69	4.62	2.62	2.69	4.62	2.62	3.62	5.85	3.25	3.56	6.09	3.56
	2500	3.19	3.19	2.50	3.19	5.50	2.50	3.19	5.62	2.50	3.88	6.91	"	3.81	7.16	3.63
<b>Raised Face</b> 	150	3.75	2.94	3.88	3.75	2.94	3.94	3.88	2.94	4.06	4.81	3.50	5.56	4.62	3.50	5.69
	300	3.94	"	4.06	3.94	"	4.12	4.12	"	4.31	5.06	"	5.81	4.88	"	5.93
	600	4.19	"	4.31	4.18	"	4.38	4.38	"	4.56	5.37	"	6.12	5.25	"	6.31
	900-1500	5.00	4.62	4.62	5.19	4.62	5.12	5.31	4.62	5.25	6.62	5.85	6.25	7.19	6.09	7.19
	2500	6.00	5.50	5.25	6.06	5.50	5.38	6.44	5.62	5.75	8.00	6.91	7.38	8.44	7.15	8.25
<b>RTJ</b> 	150							4.06	2.94	4.37	5.00	3.50	5.75	4.81	3.50	5.88
	300	4.09	2.94	4.22	4.12	2.94	4.31	4.31	2.94	4.62	5.25	"	6.00	5.12	"	6.19
	600	4.19	"	4.28	4.18	"	4.38	4.38	"	4.68	5.38	"	6.12	5.31	"	6.38
	900-1500	5.00	4.62	4.62	5.19	4.62	5.50	5.31	4.62	5.12	6.62	5.85	6.25	7.25	6.09	7.25
	2500	6.00	5.50	5.25	6.06	5.50	5.38	6.44	5.62	5.75	8.06	6.91	7.44	8.50	7.16	8.31
<b>NPT</b> 	150	2.25	2.94	2.38	2.25	2.94	2.38	2.25	2.94	2.38	3.00	3.50	3.62	3.00	3.50	3.81
	300	"	"	"	"	"	"	"	"	"	"	"	"	"	"	"
	600	"	"	"	"	"	"	"	"	"	"	"	"	"	"	"
	900-1500	2.75	4.62	"	2.75	4.62	2.62	2.75	4.62	2.62	3.75	5.85	3.25	3.75	6.09	3.56
	2500	3.25	5.50	2.50	3.25	5.50	2.50	3.25	5.62	2.50	4.00	6.91	3.25	4.00	7.16	3.63
<b>Bonnet Ext.</b> Add this dimension to 'B' (above)	150-600	4.5			4.5			4.5			4.5			4.5		
	900-1500	4.5			4.5			4.5			5.5			5.5		
	2500	4.5			4.5			4.5			5.5			5.5		
<b>Bellows Seal</b> Add this dimension to 'B' (above)	150-600	12.66			12.66			12.66			16.0			16.0		
	900-1500	12.66			12.66			12.66			16.0			16.0		
<b>Clearance</b> Above Actuator Required for Disassemble	150-600	2.50			2.50			2.50			4.25			4.75		
	900-1500	3.50			3.50			3.50			4.50			4.50		
	2500	3.50			3.50			3.50			4.50			4.50		

## Valtek Mark Two

### Offset and Angle Cryogenic Dimensions

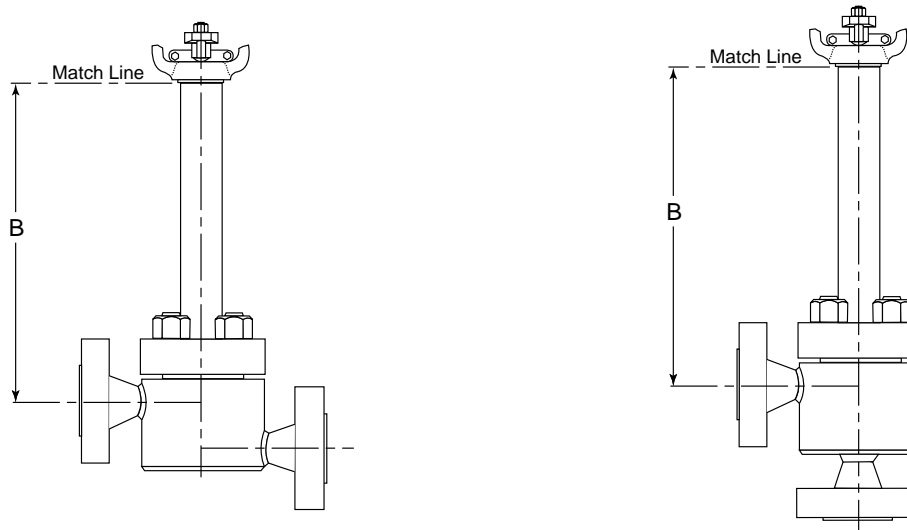

Body Size	Body Rating	B (Body Center Line to Match Line)								
		13.12	16.12	19.12	22.12	25.12	28.12	31.12	34.12	37.12
1/2	150-600	13.12	16.12	19.12	22.12	25.12	28.12	31.12	34.12	37.12
	900-1500	14.81	17.81	20.81	23.81	26.81	29.81	32.81	35.81	38.81
	2500	15.69	18.69	21.69	24.69	27.69	30.69	33.69	36.69	39.69
3/4	150-600	13.12	16.12	19.12	22.12	25.12	28.12	31.12	34.12	37.12
	900-1500	14.81	17.81	20.81	23.81	26.81	29.81	31.81	35.81	38.81
	2500	15.69	18.69	21.69	24.69	27.69	30.69	33.69	36.69	39.69
1	150-600	13.12	16.12	19.12	22.12	25.12	28.12	31.12	34.12	37.12
	900-1500	14.81	17.81	20.81	23.81	26.81	29.81	32.81	35.81	38.81
	2500	15.81	18.81	21.81	24.81	27.81	30.81	33.81	36.81	39.81
1 1/2	150-600	12.06	15.06	18.06	21.06	24.06	27.06	30.06	33.06	36.06
	900-1500	14.41	17.41	20.41	23.41	26.41	29.41	32.41	35.41	38.41
	2500	15.47	18.47	21.47	24.47	27.47	30.47	33.47	36.47	39.47
2	150-600	12.18	15.18	18.18	21.18	24.18	27.18	30.18	33.18	36.18
	900-1500	14.65	17.65	20.65	23.65	26.65	29.65	32.65	35.65	38.65
	2500	15.78	18.78	21.78	24.78	27.78	30.78	33.78	36.78	39.78

## Valtek Mark Two

### In-line Cryogenic Dimensions

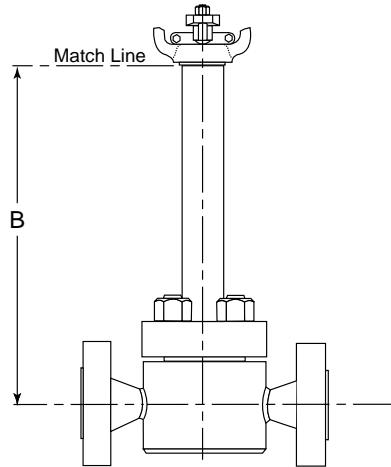

Body Size	Body Rating	B (Body Center Line to Match Line)								
1/2	150-600	14.25	17.25	20.25	23.25	26.25	29.25	32.25	35.25	38.25
	900-1500	16.31	19.31	22.31	25.31	28.31	31.31	35.31	37.31	40.31
	2500	17.44	20.44	23.44	26.44	29.44	32.44	35.44	38.44	41.44
3/4	150-600	14.44	17.44	20.44	23.44	26.44	29.44	32.44	35.44	38.44
	900-1500	16.31	19.31	22.31	25.31	28.31	31.31	35.31	37.31	40.31
	2500	17.31	20.31	23.31	27.31	29.31	32.31	35.31	38.31	41.31
1	150-600	14.44	17.44	20.44	23.44	26.44	29.44	32.44	35.44	38.44
	900-1500	16.25	19.25	22.25	25.25	28.25	31.25	34.25	37.25	40.25
	2500	17.62	20.62	23.62	26.32	29.32	32.62	35.62	38.62	41.62
1 1/2	150-600	13.94	16.94	19.94	22.94	25.94	28.94	31.94	34.94	37.94
	900-1500	17.50	20.50	23.50	26.50	29.50	32.50	35.50	38.50	41.50
	2500	17.50	20.50	23.50	26.50	29.50	32.50	35.50	38.50	41.50
2	150-600	14.06	17.06	20.06	23.06	26.06	29.06	32.06	35.06	38.06
	900-1500	17.16	20.16	23.16	26.16	29.16	32.16	35.16	38.16	41.16
	2500	17.16	20.16	23.16	26.16	29.16	32.16	35.16	38.16	41.16

Flowserve Corporation has established industry leadership in the design and manufacture of its products. When properly selected, this Flowserve product is designed to perform its intended function safely during its useful life. However, the purchaser or user of Flowserve products should be aware that Flowserve products might be used in numerous applications under a wide variety of industrial service conditions. Although Flowserve can (and often does) provide general guidelines, it cannot provide specific data and warnings for all possible applications. The purchaser/user must therefore assume the ultimate responsibility for the proper sizing and selection, installation, operation and maintenance of Flowserve products. The purchaser/user should read and understand the Installation Operation Maintenance (IOM) instructions included with the product, and train its employees and contractors in the safe use of Flowserve products in connection with the specific application.

While the information and specifications presented in this literature are believed to be accurate, they are supplied for informative purposes only and should not be considered certified or as a guarantee of satisfactory results by reliance thereon. Nothing contained herein is to be construed as a warranty or guarantee, express or implied, regarding any matter with respect to this product. Because Flowserve is continually improving and upgrading its product design, the specifications, dimensions and information contained herein are subject to change without notice. Should any question arise concerning these provisions, the purchaser/user should contact Flowserve Corporation at any of its worldwide operations or offices.

For more information, contact:

For more information about Flowserve and its products, contact [www.flowserve.com](http://www.flowserve.com) or call USA 972 443 6500



**Regional Headquarters**

**Quick Response Centers**

1350 N. Mt. Springs Prkwy.  
Springville, UT 84663  
Phone 801 489 8611  
Facsimile 801 489 3719

5114 Railroad Street  
Deer Park, TX 77536 USA  
Phone 281 479 9500  
Facsimile 281 479 8511

12 Tuas Avenue 20  
Republic of Signapore 638824  
Phone (65) 862 3332  
Facsimile (65) 862 4940

104 Chelsea Parkway  
Boothwyn, PA 19061 USA  
Phone 610 497 8600  
Facsimile 610 497 6680

12, av. du Québec, B.P. 645  
91965, Courtaboeuf Cedex, France  
Phone (33 1) 60 92 32 51  
Facsimile (33 1) 60 92 32 99

1300 Parkway View Drive  
Pittsburgh, PA 15205 USA  
Phone 412 787 8803  
Facsimile 412 787 1944

Flowserve and Valtek are registered trademarks of Flowserve Corporation.