



Valtek MaxFlo 3

High Capacity Rotary Eccentric Plug Control Valve



Experience In Motion

Valtek MaxFlo 3 Control Valves



Figure 1: MaxFlo 3 Control Valve with Diaphragm Actuator



Figure 2: MaxFlo 3 Control Valve with Cylinder Actuator



Figure 3: Robust, Reliable Flanged End Plug Design

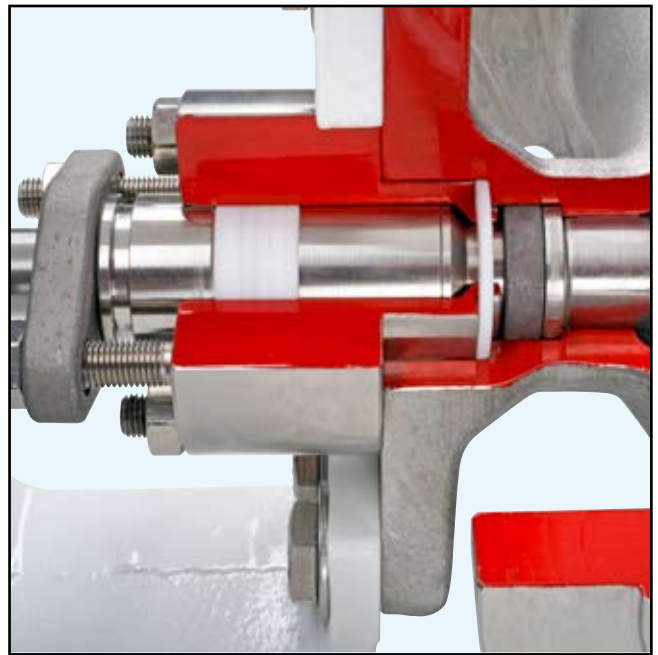

Figure 4: Safe, Reliable, Anti-Blowout Shaft System

Valtek MaxFlo 3 Control Valves

Introduction

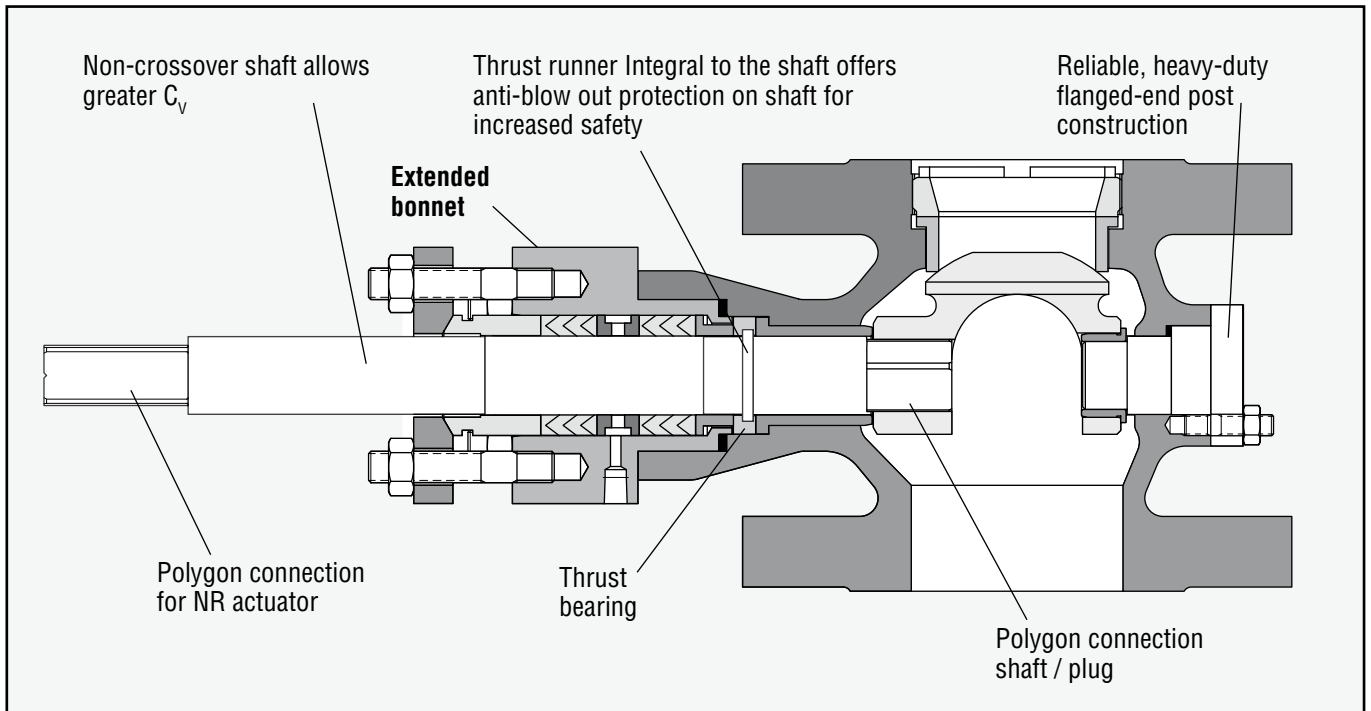

Figure 5: MaxFlo 3 Rotary Eccentric Plug Control Valve, Body Subassembly

MaxFlo 3 raises the bar to the highest standards of reliability

High Performance

The Valtek MaxFlo 3 control valve is a high-performance, eccentric rotary plug design, which is used in low-pressure, high C_v applications. The MaxFlo 3 valve is capable of operating temperatures between -100° to 750° F / -73° to 400° C.

The MaxFlo 3 eccentric plug offers rangeability up to 160:1 – compared to 50:1 for typical globe valves and 20:1 for most butterfly valves.

A heavy-duty, non-crossover shaft is out of the valve's flow path. This superior design allows higher flow capacity for a given valve size. It also eliminates shaft damage from erosive process fluids. Many other manufactures' designs allow the shaft to crossover the flow path, resulting in lower flow capacity and shaft wear.

The MaxFlo 3 control valve is available in 1- through 12-inches DN 25 - 300 in flanged or flangeless body design in different face-to-face dimensions in a flanged body style (ANSI Classes 150 and 300 / PN 16 to 40). Multiple reduced trims for each valve size are available. These trim reductions allow a wide range of C_v values in each valve size, providing accurate, precise control across the capacity of the valve with extremely fine resolution.

The positioners offered on the MaxFlo 3 allow the control valve to respond to small signal changes without overshoot. The P5, EP5, Logix 500si and Logix 3000IQ positioners can respond

precisely to 0.1 percent signal changes. This accuracy allows the MaxFlo 3 control valve to precisely control the process fluid.

As the valve opens and the plug rotates smoothly out of the seat (Figure 6), the chances of water hammer are significantly reduced. And, since the plug and non-crossover shaft do not obstruct the flow, the MaxFlo 3 valve obtains a higher flow coefficient (C_v) rating than other traditional rotary valves. This is why Maxflo 3 can obtain a rangeability of 160:1. In addition, the MaxFlo 3 design has a zero breakout torque requirement, which allows smaller actuators to be used — reducing costs and maintenance time.

Designed to eliminate common failure problems associated with splines and keyed shaft attachments, the polygon connection is a proven superior method for making demanding mechanical connections that are stronger, more precise and have a substantially longer service life.

All these features make the MaxFlo 3 control valve the most accurate, precise, eccentric rotary plug valve on the market. High performance is the first key point in the core design principles behind the MaxFlo 3 control valve.

Valtek MaxFlo 3 Control Valves

Introduction

Increased Safety

An additional point in the core design principles behind the MaxFlo 3 control valve was increased safety. ANSI B16.34 section 6.5.1 states valves should be designed to prevent the stem from being removed while the valve is under pressure. Flowserve has taken this safety issue one step further. The unique MaxFlo 3 stem, with the integral thrust runner on the shaft, cannot be removed unless the bonnet nuts are removed (See Figure 5). Many other rotary control valves do not include anti-blow out protection on shaft; designs offering anti-blow out protection lack the robust character MaxFlo 3 control valves provide (See Figure Nos. 2 and 5). Accidents, safety incidents and failures have been attributed to other valves lacking the unique features of the MaxFlo 3 control valve.

The MaxFlo 3 control valve's durable flanged endpost design eliminates all possibility of any parts coming loose and traveling downstream. The flanged end post is held in place by four bolts. It can't come loose like other manufacturers' designs; thus eliminating any leak path. The MaxFlo 3 plug design will either fail-open (shaft downstream) or closed (shaft upstream) in the event of air or instrument signal loss.

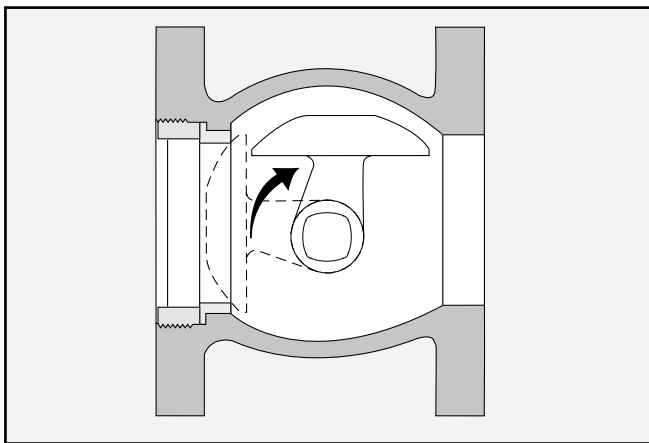

Figure 6: MaxFlo 3 Plug – Open

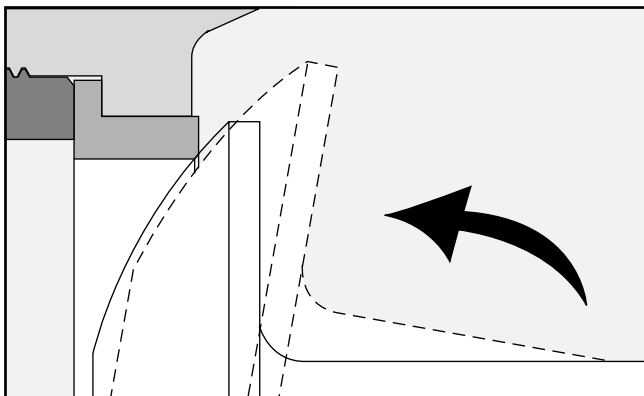

Figure 7: MaxFlo 3 Plug – Closing

Long Life

Longer life is also a key principle behind the MaxFlo 3 control valve. Its oversized shaft eliminates shaft failures and provides a large shaft bearing surface, reducing bearing wear, improving reliability and increasing the life of the valve. The plug is produced from 1.4418 hardened material to increase plug life, provide tight shutoff and increase reliability in a wide range of difficult-to-handle applications (including flashing, erosive, mild cavitation and steam services). The rugged plug design reduces valve failure caused by water hammer.

The non-crossover shaft allows for uninterrupted flow. When the valve is in the open position, the fluid flow is not deflected into the seat or retainer, providing greater reliability — even after years of service. The durable flanged endpost design provides a robust bearing surface. Since the endpost is held in place by four bolts, it can't come loose in service like other manufacturers' designs (see Figure 4).

The typical maintenance cycle for the MaxFlo 3 valve exceeds five years and more than 20 years for total valve cycle expectancy. Most MaxFlo 3 actuators have a cycle life exceeding one million cycles, making the MaxFlo 3 design one of the most reliable control valves on the market.

NACE certification is available with the MaxFlo 3 design. Special Flowserve packing sets, such as SureGuard™ packing, are available to control fugitive emissions and to meet Environmental Protection Agency (EPA) requirements.

The MaxFlo 3 double-offset eccentric plug rotates into the seat at an angle that eliminates sliding over the seat surface (Figure 7). The design reduces seat wear, and thereby decreases maintenance requirements and costs. At the same time, a tight ANSI Class VI shutoff is easily obtainable using the soft seat design.

The shafts polygon connections provide the highest torque carrying capacity within the shaft diameter of any shaft connection. The smooth polygon profile, with no sharp corners, eliminates stress peaks within the connections; hence providing twice the shear strength of involute splines.

This reduces backlash and the high strength of the polygon connections makes them capable of withstanding greater shock loads under extreme torque reversal conditions.

Valtek MaxFlo 3 Control Valves

Features and Advantages

High Performance

Features	Advantages
High flow coefficients	Up to 70 percent more flow than other manufacturers' rotary eccentric plug designs (reduced trims also available).
Non-crossover shaft	Shaft is out of flow path for higher flow capacities and less erosion damage. Valve may be used in paper pulp concentrations to 3 percent
Polygon connections	Reduces backlash
High rangeability	For high rangeability up to 160:1. Rangeability due to non-crossover shaft design. Allows accurate throttling ability over a very wide range.
Accurate throttling	Plug throttles without contacting seat.
High-performance positioners	P5, EP5, Logix 500si and Logix 3000IQ positioners provide precise, accurate process control by responding to signal changes of 0.1 percent without overshoot.
High control	Rangeability up to 160:1.
Bidirectional shutoff	Allows valve to be mounted with shaft upstream or downstream
Flanged	ANSI Classes 150-300 (PN 16-40)
Reduced trims	Available in 100, 75/70 and 40 percent (For other reductions, please contact your Flowserve representative)
Operating temperatures	-148° F to 750° F (-100° C to 400° C)
Sizes	1, 1½, 2, 3, 4, 6, 8, 10, 12 (inches) DN 25, 40, 50, 80, 100, 150, 200, 250, 300
Face-to-Face	ISA 75.08.02 flanged and flangeless (ANSI - DIN) ISA 75.08.01 flanged ANSI DIN 3202 F1 flanged DIN
Shutoff rating (ANSI)	Metal seat: Class IV / Soft seat: Class VI

Increased safety

Superior quality	Standard shaft and trim materials allow higher pressure drops than other manufacturers' rotary eccentric plug designs, especially in NACE applications. Rugged and lightweight for easy handling and maintenance.
Safe, anti-blowout shaft	While conventional rotary control valves do not offer anti-blow out shafts, the unique MaxFlo 3 shaft design alleviates this problem. This feature also minimizes the risk of personal injury, fire and severe process leakage due to shaft blow out. During disassembly, removal of the valve shaft requires the removal of the bonnet nuts.
Reliable end post design	The heavy-duty flanged end post construction ensures no parts of the valve can duty end post construction come loose and enter process line. Also, because of the robust flange, the gasket is uniformly compressed, thus eliminating leakage from the end post bore.
Fluid-assisted fail action	Fluid assists the plug to fail-open or fail-closed upon air failure.

Long Life

Robust post design	Post or other parts cannot come loose in service and travel downstream.
Eccentric rotary plug	No breakout torque. Plug lifts off seat immediately, reducing seat wear.
Rugged plug design	1.4418 hardened plug is standard material.
Polygon connections	Provide twice the strength of involute spline. Eliminates stress peaks within the connections
NACE certification	Allows valve's use in petrochemical applications.
Multiple packing options	Configurations/materials available for most applications. Fugitive emission options meet EPA requirements.
Certifications	NACE, Certified material test report
External Bonnet	The external bonnet increases packing life and allows easier maintenance

Valtek MaxFlo 3 Control Valves

Specifications

Table I: Body Specifications

Sizes	1" - 12" / DN25 - 300
End Connection	Flanged, Flangeless (1 - 8")
Body rating	ANSI Class 150-300 / PN 16-40
Trim Area	100% (full), 75/70% reduction, 40% reduction 25/15% reduction
Shutoff rating	ANSI Class IV, ANSI Class VI with soft seat
Operating temperature	-148° to 752° F / -100° to 400° C
Pneumatic Actuator	Diaphragm: NR1, NR2, NR3 Cylinder: 25, 50, 100, 200 Manual
Characteristics	Linear, equal percent
Fail Mode	Air-to-close, air-to-open, lock-in-place

MaxFlo 3 Sizing Procedure and Data

Procedures and data to size MaxFlo 3 valves – including determining actuator size – are contained in the *Performance!* valve sizing program.

Table II: Materials of Construction

Body	Carbon steel A216 WCC, WN 1.0619 Stainless steel A351 CF8M, WN 1.4408
Plug	1.4418 hardened, 316L w/Alloy 6 overlay
Shaft	1.4418 hardened, A453 Gr 660
End Post	1.4418 hardened, A453 Gr 660
Bearings	440C, UNSS31803 (Duplex 2205)
Sealed Bearings	440C, UNSS31803 (Duplex 2205)
Seat Retainer	Stainless steel (A351 CF8M), 8-inch and smaller (A182 G F6 400 series SS for 10/12-inch valves).
Seat Ring	316L Stainless steel, 316L w/Alloy 6 overlay, 416 HT
Soft Seat	PTFE
Packing	PTFE V-ring, Graphite rib/braid, SureGuard, SafeGuard (XT and Firesafe)

Table III: Maximum Allowable ΔP^*

Valve Size (inches/mm)	Maximum Allowable Differential Pressure	
	psi	bar
1-8/ 25-200	725	50
10/ 250	450	31
12/ 300	320	22

* Actual data dependent on trim size and material, actuator size, and shaft orientation. Allowable drop should be determined after detailed sizing is complete in *Performance!* valve sizing software.

Table IV: Maximum Flow Capacity (C_v)

Body Size (inches/mm)	Trim Size											
	100				75/70				40			
	Shaft Direction											
	Up		Down		Up		Down		Up		Down	
	Metal	Soft	Metal	Soft	Metal	Soft	Metal	Soft	Metal	Soft	Metal	Soft
1/ 25	21	12	18	10	15	8	13	7	8	6	7	6
1½/ 40	50	42	47	39	35	35	33	33	20	20	19	19
2/ 50	78	69	80	71	43	43	52	52	24	24	32	32
3/ 80	214	214	241	241	167	167	182	182	95	95	104	104
4/ 100	302	302	405	405	220	220	267	267	150	150	170	170
6/ 150	730	730	955	955	567	567	669	669	324	324	382	382
8/ 200	1130	1130	1700	1700	847	847	1275	1275	Not available			
10/ 250	1785	1785	2505	2505	1339	1339	1879	1879				
12/ 300	2560	2560	3600	3600	1920	1920	2700	2700				

Valtek MaxFlo 3 Control Valves

Diaphragm Actuator

The Flowserve diaphragm rotary actuator is a rugged single-acting actuator designed to provide high performance, long life and reliability. It operates with air supply pressures from 20 to 60 psi (1.4 to 4.0 bar) and is field-reversible. High performance is assured with ball bearing internal action, which avoids the friction associated with O-Rings. The diaphragm actuator is very sensitive to small changes in air supply, which allows it to precisely move the valve plug with out over shoot. This is also enhanced by the direct polygon coupling between the valve shaft and actuator stem which eliminates backlash. Long life is assured with the high-cycle diaphragm and a durable steel diaphragm housing and cast iron yoke transfer case. Other features include a convenient push-type jackscrew handwheel, an easily viewed external plug position indicator, and an adjustable stroke stop that prevents excessive rotation.

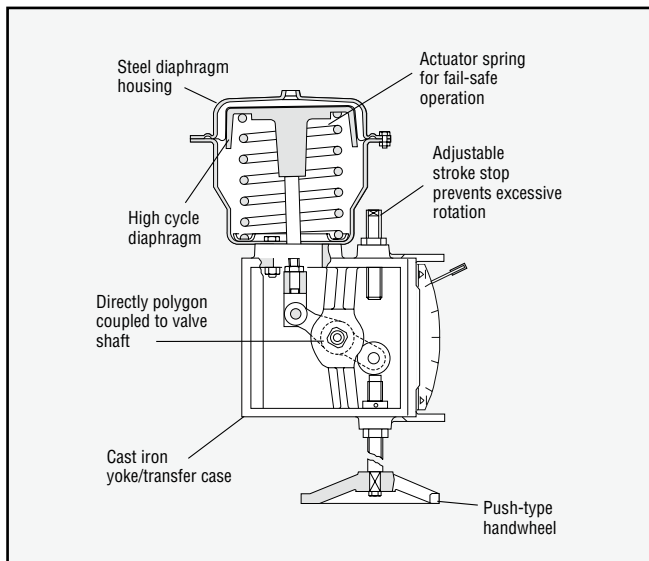

Table V: Diaphragm Actuator Selection Guidelines

A diaphragm actuator should be applied when the process requires the following:
1. Single-acting action
2. Field-reversible design
3. Low supply pressure (20 - 60 psi / 1.4 - 4.0 bar)
4. High controllability (ball bearing, no O-ring friction)
5. Handwheel (push-only)
6. Materials must include steel diaphragm casing, cast iron yoke
7. 60° or 80° shaft rotation, depending on trim size

Spring Cylinder Rotary Actuator

The Flowserve spring cylinder rotary actuator combines high torque and pneumatic stiffness with excellent throttling capabilities. These characteristics are designed into a lightweight, rugged and compact assembly, making the Flowserve rotary actuator an excellent choice for quarter-turn applications. Flowserve analog and digital positioners are available for throttling applications. The Flowserve cylinder actuator and positioner are designed for supply pressures up to 150 psi* (10.3 bar), making very high torques attainable. The actuator uses a rocking piston for direct conversion of linear motion to rotary motion. The rocking piston assembly eliminates lost motion.

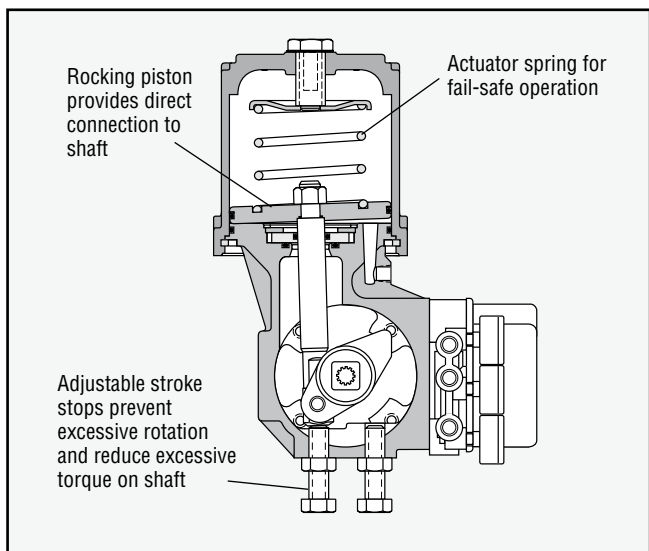

Table VI: Spring Cylinder Rotary Actuator Selection Guidelines

A cylinder actuator should be applied when the process requires the following:
1. Double acting
2. Field reversible
3. Lightweight, compact design
4. High stiffness (for throttling near seat)
5. Actuation speed \leq 1 sec
6. High supply pressure (50 - 150 psi / 3-10 bar)
7. Interchangeability with Flowserve rotary products (Valdisk, Valdisk 150 and ShearStream)
8. Aluminum cylinder/piston, cast iron yoke
9. 90° shaft rotation

Figure 9: Spring Cylinder Rotary Actuator

Flowserve Essen GmbH

Manderscheidtsrasse 19
45141 Essen
Germany
Phone: +49 (0) 201 89 19 0
Fax: +49 (0) 201 89 19 662

Flowserve S.A.S.

12, avenue du Quebec
B.P. 645
91965 Courtaboeuf Cedex
France
Phone: 33 (0) 1 60 92 32 51
Fax: 33 (0) 1 60 92 32 99

Flowserve (Austria) GmbH

Control Valves - Villach Operation
Kasernengasse 6
9500 Villach
Austria
Phone: +43 (0) 4242 41181-0
Fax: +43 (0) 4242 4118150

To find your local Flowserve representative:

For more information about Flowserve Corporation, visit
www.flowserve.com

FCD VLEEBR0052-02 07.07

All data subject to change without notice

©02.2007 Flowserve Corporation. Flowserve is a trademark of the Flowserve Corporation