



TECHNICAL BULLETIN

Logix 3000MD Series Digital Positioner



Experience In Motion

The Logix 3000MD Series Digital Positioner - How It Works

Logix 3000MD Positioner Overview

Figure 1: System Positioning Algorithm for Logix 3400MDDigital Positioners

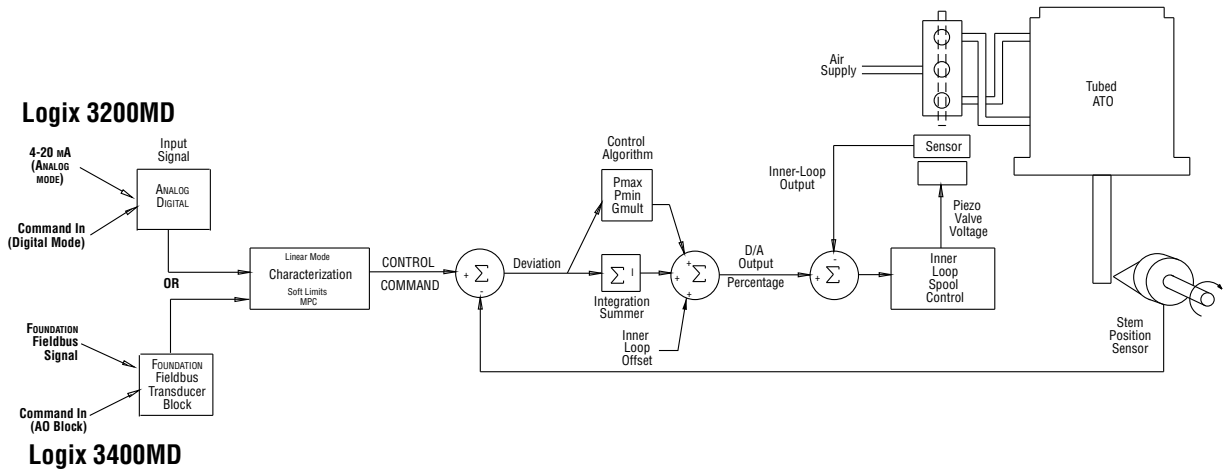
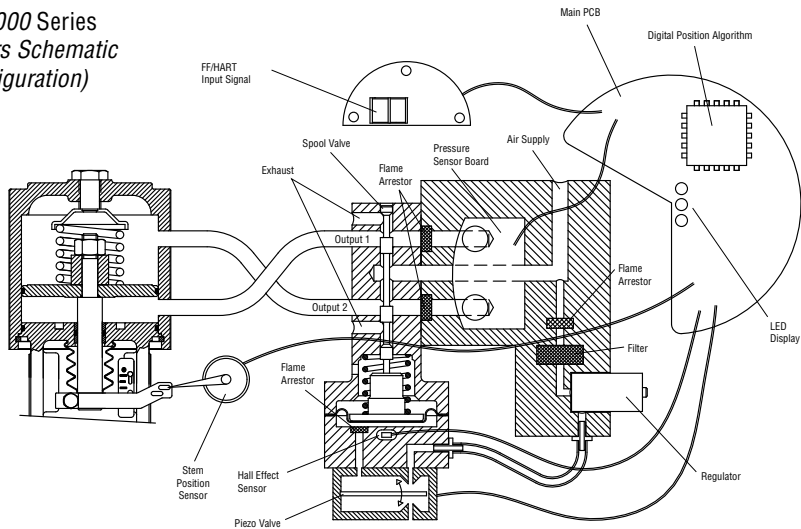

Figure 1: Logix 3000 Series Digital Positioners Schematic (air-to-open configuration)



TUNING

Unlike other positioners that have only one set gains to set the response of the positioner, the Logix 3200MD positioner uses a multi-variable variable gain tuning algorithm. This allows the positioner to make large step changes with minimal overshoot, while achieving the resolution to respond to very small step changes.

The Auto Tune procedure cycles the actuator to produce a measured response and selects those gain values that provide appropriate actuator performance. The Auto Tune function includes a gain modifier selector that can be used to increase or decrease the calculated gain in order to achieve optimal performance.

By setting the Auto Tune on/off DIP switch, the tuning mode can be changed from auto to manual. The Logix 3000MD Series positioners provide several preset gain settings with a locally adjustable gain set selector directly from the user interface on the positioner. If custom settings are desired, tuning sets can be modified with a handheld or ValveSight, to accommodate a wide range of actuator sizes and types.

Time is Money

Shorter commissioning time gets you up and running, making money faster

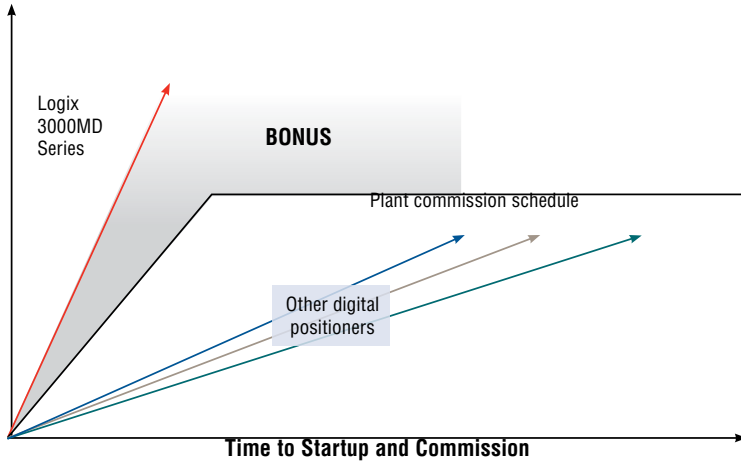

3000MD Series Facts

3400

- Three versions: Basic, Advanced (Advanced includes pressure sensors), and Pro (Pro includes pressure sensors and full featured valve diagnostics)
- ITK - CFF 4.6, 5.0
- DD available at www.fieldbus.org or www.flowserve.com
- Stores a valve signature onboard in NVRAM
- Linkable Position Feedback as part of the AO Function block.
- Contains: AO, PID, 2-DI, DO, OS, IS function blocks.
- Onboard temperature sensor to measure local positioner ambient
- Stroke speed limiter (configurable in transducer block)
- Stainless steel version available
- DTM Available

3200

- Three versions: Basic, Advanced (Advanced includes pressures), Pro (Pro includes pressure sensors and full featured valve diagnostics)
- HART Command 1, 3, 9, 33 & 48
- Burst Mode available to continuously transmit
 - Position command analog loop current
 - Final value of command after characterization
 - Supply pressure (advanced), Temperature (basic)
 - Stem position in percent
- Onboard temperature sensor to measure local positioner ambient
- Stroke speed limiter (configurable through HART)
- Stainless steel version available
- Enhanced Device Description for advanced signature diagnostics
 - Step test, friction test, HRL, data logger
- DTM Available

The Logix 3400MD for FOUNDATION Fieldbus Applications

Complete local configuration, on any valve/actuator and local.

FF Simulate – Run a control strategy without process

FF Write Protect – Locks out unauthorized writes to NVRAM

FOUNDATION Fieldbus made easy.

(In OOS) Calibrate stroke and adjust tuning without entering the Transducer Block —Updates the Block when complete.

36 status and alert and messages displayed locally via three easy-to-read LEDs



Logix 3400MD Features	
RFI/EMI Immunity	✓
FISCO Compliant, User Interface	✓
Polarity Insensitive UI (Potted UI)	✓
AO Block (30mS)	✓
PID Block (6 PID Equations) (90mS)	✓
2 DI Block (20mS)	✓
1 DO Block (30mS)	✓
1 IS Block (50mS)	✓
1 OS Block (50mS)	✓
LAS (Link Master Device)	✓
Auto Tune (Positioner Performance)	✓
High Friction Stability	✓
FF Code Download	✓
Flash Ram (Local Positioner Embedded Code Upgrade)	✓
Local Valve Signature Storage	✓
Local Calibration and Setup (While in OOS)	✓
24/7 Local Fault Monitoring	✓
Local Adjustable Gain	✓
Wizard/Method for On-line Commissioning	✓

Logix 3400MD Features	
Local Jog Buttons to Adjust 100% Command Position (While in OOS)	✓
Linkable Position feedback (AO Read Back)	✓
Four Response Curves (Linear, =%, QO, and Custom) Locally Activated, or Through FF	✓
Multiple View Objects in Transducer Block	✓
Honeywell PKS Partner with FDM	✓
Methods Setup Wizard	✓
DTM Available	✓
Yokogawa VIP Partner & PRM supported	✓
Honeywell PKS Advantage Partner	◇



Flowserve is a Honeywell Partner, with Flowserve DTM support pending in the ExperionDCS Field Device Manager. Please contact your Honeywell representative for details.

The Logix 3200MD for HART Applications

Complete local configuration, just like the Logix 3400MD, but HART protocol

- Local status and alert messages
- Tuning (Auto Tune function and manual adjustment)
- Jog buttons to manually adjust 100% position
- Easy-to-install 4-20 mA analog feedback card option

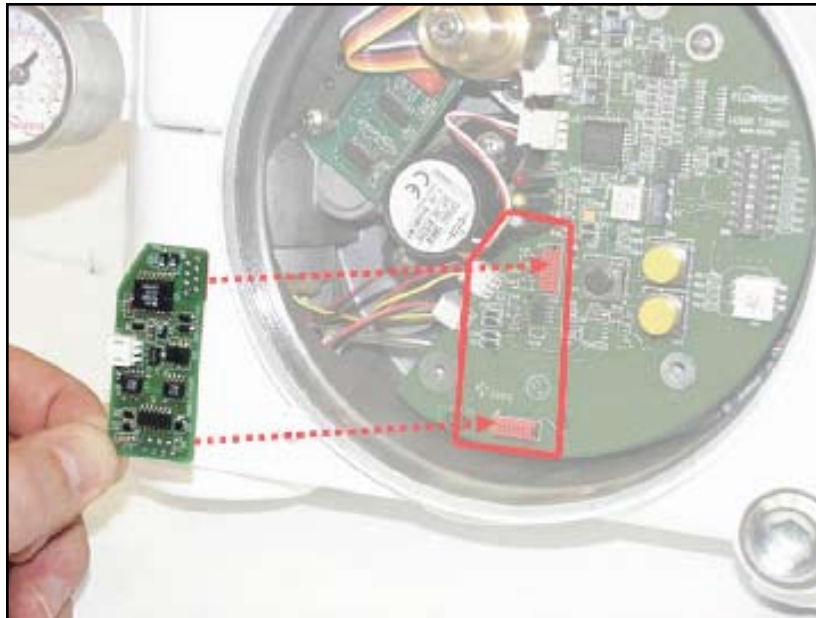

Simple plug-in AO card, automatically zero and spans position feedback during Quick Cal

Logix 3200MD Features	
RFI/EMI Immunity	✓
Auto Tune (Positioner Performance)	✓
High Friction Stability Tuning	✓
Integral 4-20 mA Feedback Option	✓
Flash RAM (Local Positioner Embedded Code Upgrade)	✓
Local Valve Signature Storage	✓
Local Calibration and Setup	✓
24/7 Local Fault Monitoring	✓
Local Adjustable Gain	✓
Three Response Curves (Linear, =% and custom)	✓
Local Jog Buttons to Adjust 100% Command Position	✓
Valve Signature Diag. "Valve Analysis" AMS SnapOn® Application	✓
AMS Device Manager	✓
DTM Available	✓
Yokogawa VIP Partner	✓
Honeywell PKS Partner with Honeywell HART FDM	✓



ValveSight Dashboard for Logix 3200MD or 3400MD
Advanced DTM and Pro diagnostics



The Logix 3000MD Series Positioners – no software or hand-held device required... easy as 1, 2, 3



With the Logix 3400MD, function blocks are no longer required to set up, configure and perform a simple stroke calibration. The 3400MD can be set up with 9-32 VDC supply and 45 psi (min.) air supply on any valve/actuator platform.

Calibration, configuration and tuning parameters from the local interface will be automatically updated in the Transducer Block on the Logix 3400MD. Local setup and calibration that does not require a link to a host controller, PC or hand-held device, as well as local validation that setup is correct, make any FOUNDATION Fieldbus™ installation easy and straightforward.

When the 3400MD is in OOS (Out Of Service mode), the local interface shown to the right is accessible and setup can be carried out through the following steps:

Common Configuration Steps

1. Make sure the mechanical linkage, air tubing and actuator mounting are correct.
2. Set the configuration switches to the desired operation of the valve/actuator.
3. Set the quick calibration switch to Jog or Auto. In Jog, the 100% position can be manually adjusted using the yellow up and down buttons after Re-Cal is pressed. In Auto, the positioner finds the 100% position and calibration is complete. LED blink codes will guide the user through the process. Four green blinks (GGGG) or (GGGY) at the end of the sequence confirm that the calibration was successful.
4. If needed, the GAIN switch located to the right of the jog buttons will speed up or slow down the positioner's response to command changes. With the Auto Tune configuration switch set to "On", the positioner's algorithm will select a gain with no over-shoot. The 'E' position of the rotary GAIN dial indicates "neutral" with respect to gain adjustment. Turning clockwise from E to H and will speed up the response. Tuning counter-clockwise from E will slow it down, with A being the slowest response.

The Logix 3200MD can be set up with 10 VDC milliamp current supply current and 45 psi (min.) air supply on any valve/actuator platform.

Calibration, configuration and tuning parameters from the local interface will be automatically updated in the HART registers on the Logix 3200MD. Local setup and calibration that does not require a link to a host controller, PC or hand-held device, and local validation that setup is correct make any HART™ installation easy and straightforward.

With the Logix 3200MD, the local interface shown to the right can be used to set up the unit in seconds through the following steps:



There's a Flowserve Expert Inside - ValveSight FDT/DTM Technology

FLOWSERVE'S VALVESIGHT DTM SOFTWARE HELPS MANAGE FIELD DEVICES BY COMBINING THE FEATURES OF FIELD NETWORK HARDWARE AND THE HART (3200MD) OR FOUNDATION FIELDBUS (3400MD) COMMUNICATION PROTOCOLS USING FDT/DTM TECHNOLOGY WITH THE LOGIX 3000MD SERIES POSITIONERS. VALVESIGHT IS A COMPLETE SOFTWARE PACKAGE, FEATURING A UNIQUE AND EASY TO UNDERSTAND HEALTH STATUS OF THE DEVICE THAT SHOWS NOT ONLY PROBLEMS, BUT THE MAGNITUDE OF DEVELOPING PROBLEMS AS WELL. VALVESIGHT ALSO HAS CONFIGURATION AND CALIBRATION SCREENS TO FULLY SUPPORT THE LOGIX 3000MD POSITIONER FAMILY. ADDITIONALLY, THE USER CAN ACCESS CUSTOMIZED REPORTS FOR ALL CONFIGURATION, CALIBRATION AND EVENT DATA. FLOWSERVE'S VALVESIGHT DTM OPENS THE 'WINDOW' TO THE DEVICE AND ALLOWS IMMEDIATE VIEWS WITH LIVE FEEDBACK ON ALL ACTIVE DEVICE SENSORS INCLUDING VALVE STEM POSITION, CONTROL SIGNAL, FRICTION, RESPONSE TIME AND OTHER IMPORTANT SYSTEM METRICS.

ValveSight DTM software enables communication between the software and field device networks using the HART or FF protocol and provides access to the 24/7 diagnostic information from field devices. Using FDT/DTM technology maintenance personnel can access any Logix 3000MD series positioner on the network from a single workstation. Additionally, the software has capability to store configuration and calibration history and view event logs for each digital positioner accessible through the network.

DIAGNOSTIC ENGINE

Users can now obtain a new level of detailed real time diagnostic information with ValveSight DTM software. ValveSight features an "Expert Inside" performing real time on-line diagnostics 24 hours a day, 7 days a week. The diagnostic assessment of the 'expert inside' is instantly displayed on the local interface and through the ValveSight DTM software. The 'health bars' in the Dashboard view instantly indicate any developing issues and quickly direct the user to the implications and solutions for each problem. The system automatically prioritizes alarms to direct the user to the root cause.

CONFIGURATION MANAGEMENT

ValveSight DTM software also allows the user to easily upload a configuration from the positioner. This means that a new replacement positioner can be identically configured with the simple click of a mouse once the correct configuration has been identified. ValveSight enables users to edit individual configurations and print a positioner configuration report.

21-POINT CHARACTERIZATION CURVE

With ValveSight DTM software, the user can adjust a 21-point characterization curve to change the response of the positioner in order to meet the process requirements. The output of each control point is independent, allowing the user to create a custom curve with very high resolution. This customized curve can be saved in the memory of the Logix 3000MD positioners, and either activated or overridden with a simple on-board selector switch.

SIGNATURES

The Logix 3000MD positioners are designed to assure that data is easily gathered, stored and compared to historical valve data so the user can determine the performance of critical valves.

With ValveSight DTM software a user-defined signature ramp or step response test can be generated with a Logix 3000MD positioner. Signatures can be saved and cataloged (and later retrieved) for comparison with a more recent signature.

A special partial stroke signature function will automatically test the valve/actuator and give a pass/fail indication.

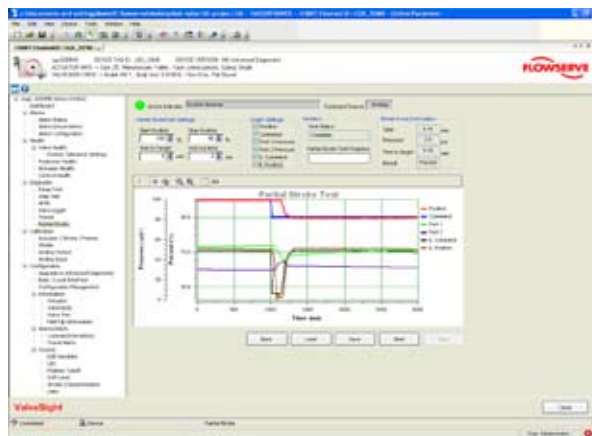

POSITIONER PERFORMANCE

Static performance and accuracy measures such as hysteresis, deadband, linearity, and repeatability can be obtained with the Logix 3000MD positioners. These values can be graphically depicted, stored and later retrieved for comparative analysis.

The Logix 3000MD Positioner Specifications

Specifications for Logix 3400MD

Table I: Electrical Specifications

Power Supply	Two-wire, 9-32 VDC FF compatible
IS	Fisco compliant
Communications	FF Protocol ITK 4.6x, 5.0
Operating Current	23 mA
Maximum Voltage	36.0 VDC

Table II: Environmental Conditions

Operating Temperature Range	Standard	-40° to 176°F (-40° to 80°C)
	Low	-40° to 176°F (-40° to 80°C)
Transport and Storage Temperature Range	-40° to 176°F (-40° to 80°C)	
Operating Humidity	0 - 100% non-condensing	

Note: The air supply must conform to ISA Standard ISA 7.0.01 (a dew point at least 18 degrees Fahrenheit below ambient temperature, particle size below five microns—one micron recommended—and oil content not to exceed one part per million).

Table III: Physical Specifications

Housing Material	Cast, powder-painted aluminum or stainless steel
Soft Goods	Buna-N / Florosilicone
Weight	8.3 pounds (3.9 kg) aluminum 20.5 pounds (9.3 kg) stainless steel

Table IV: Positioner Specifications

Deadband	<0.1% full scale
Repeatability	<0.05% full scale
Linearity	<0.5% (rotary), <0.8%, (sliding stem) full scale
Air Consumption	<0.3 SCFM (0.5 Nm ³ /hr) @ 60 psi (4 bar)
Air Supply	30-150 psig (ISA 7.0.0.1 compliant)
Air Delivery	12 SCFM @ 60 psi (0.27 Cv)

Specifications for Logix 3200MD

Table I: Electrical Specifications

Power Supply	Two-wire, 4-20 mA 10.0 to 30.0 VDC
Compliance Voltage	10.0 VDC @ 20 mA
Effective Resistance	495 Ω @ 20 mA Typical Add 20 Ω when HART communication active
Communications	HART Protocol ITK 5,6
Minimum Operating Current	3.6 mA without AO board 3.7 mA with AO board
Maximum Voltage	30.0 VDC

Table II: Environmental Conditions

Operating Temperature Range	Standard	-4° to 176°F (-20° to 80°C)
	Low	-40° to 176°F (-40° to 80°C)
Transport and Storage Temperature Range	-40° to 176°F (-40° to 80°C)	
Operating Humidity	0 - 100% non-condensing	

Note: The air supply must conform to ISA Standard ISA 7.0.01 (a dew point at least 18 degrees Fahrenheit below ambient temperature, particle size below five microns—one micron recommended—and oil content not to exceed one part per million).

Table III: Physical Specifications

Housing Material	Cast, powder-painted aluminum or stainless steel
Soft Goods	Buna-N / Florosilicone
Weight	8.3 pounds (3.9 kg) aluminum 20.5 pounds (9.3 kg) stainless steel

Table IV: Positioner Specifications

Deadband	<0.1% full scale
Repeatability	<0.05% full scale
Linearity	<0.5% (rotary), <0.8%, (sliding stem) full scale
Air Consumption	<0.3 SCFM (0.5 Nm ³ /hr) @ 60 psi (4 bar)
Air Supply	30-150 psig (ISA 7.0.0.1 compliant)
Air Delivery	12 SCFM @ 60 psi (0.27 Cv)

The Logix 300MD E.O.M. Mounting Kits

Brand	Model	Size	Mounting Kit	
Fisher	657 & 667	30	213905	
		34	141410	
		40		
		50	171516	0.5" – 1.5" stroke
			171517	2" stroke
		60	171516	0.5" – 1.5" stroke
			171517	2" stroke
		70	171518	4" stroke
	80	171519		
	1250	225	173371	
450				
675				
1052	33	171549	Rotary	
657-8	40	173798		
Neles	RC		171512	
	RD		178258	
Foxboro	Slid-Std		173567	
	Linear		178258	
Honeywell	VST-VA3R	17-in. dia.	173798	
	VSL-VA1D	12-in. dia.	173798	
Masoneilan (Linear Actuators)	37	9	171721	
		11		
		13		
		18		
		24		
	38	11	173235	
		13	173234	
		15	186070	
		18	173382*	
		24	173896	
	71 Domotor	25	173325	
		50	173335	
		100	173336	
	88	6	171722	
		16	173827	
	47	B	173361	
	48	B	173361	
	"D" Domotor	200	175141	
	71-2057AB-D		176179	
	71-40413BD		176251	

Brand	Model	Size	Mounting Kit
Masoneilan (Rotary Actuators)	33	B	173298
	35	4	173298
		6	
		7	
70	10	173298	
Valtek	Trooper	166636	0.75" – 1.50" Std
Automax	R314	141180	HD
	SNA115		NK313A
Vanguard	37/64		175128
Air-Torque	AT Series	AT0 – AT6	Consult factory
Automax	SNA Series	SNA3 – SNA2000	
	N Series	N250.300	
	R Series	R2 – R5	
Bettis	RPC Series	RP – TPC11000	
	G Series	G2009-M11 – G3020-M11	
EL-O-Matic	E Series	E25 – E350	
	P Series	P35 – P4000	
Hytork	XL Series	XL45 – XL4580	
Unitorq	M Series	M20 – M2958	
Worcester	39 Series	2539 - 4239	

*Adjustable mounting kit 173798 may be needed if handwheels are used.

NAMUR Accessory Mounting Kit Part Numbers

Bracket Option	Description
28	20 mm pinion x 80 mm bolt spacing
28	38 mm pinion x 80 mm bolt spacing
313	30 mm pinion x 80 mm bolt spacing
513	50 mm pinion x 130 mm bolt spacing
Bolt Option	Description
A	10-24 UNC bolting
B	10-32 UNF bolting
L	M5-.8 metric bolting

Example: NK313A, NAMUR Accessory Mounting Kit with 30 mm pinion x 80 mm bolt spacing and 10-24 UNC bolting.

PLEASE CONTACT YOUR FLOWSERVE REPRESENTATIVE FOR ADDITIONAL MOUNTING KIT AVAILABILITY.

3000MD Series dimensions

NOTE: Dimensions in inches (mm)

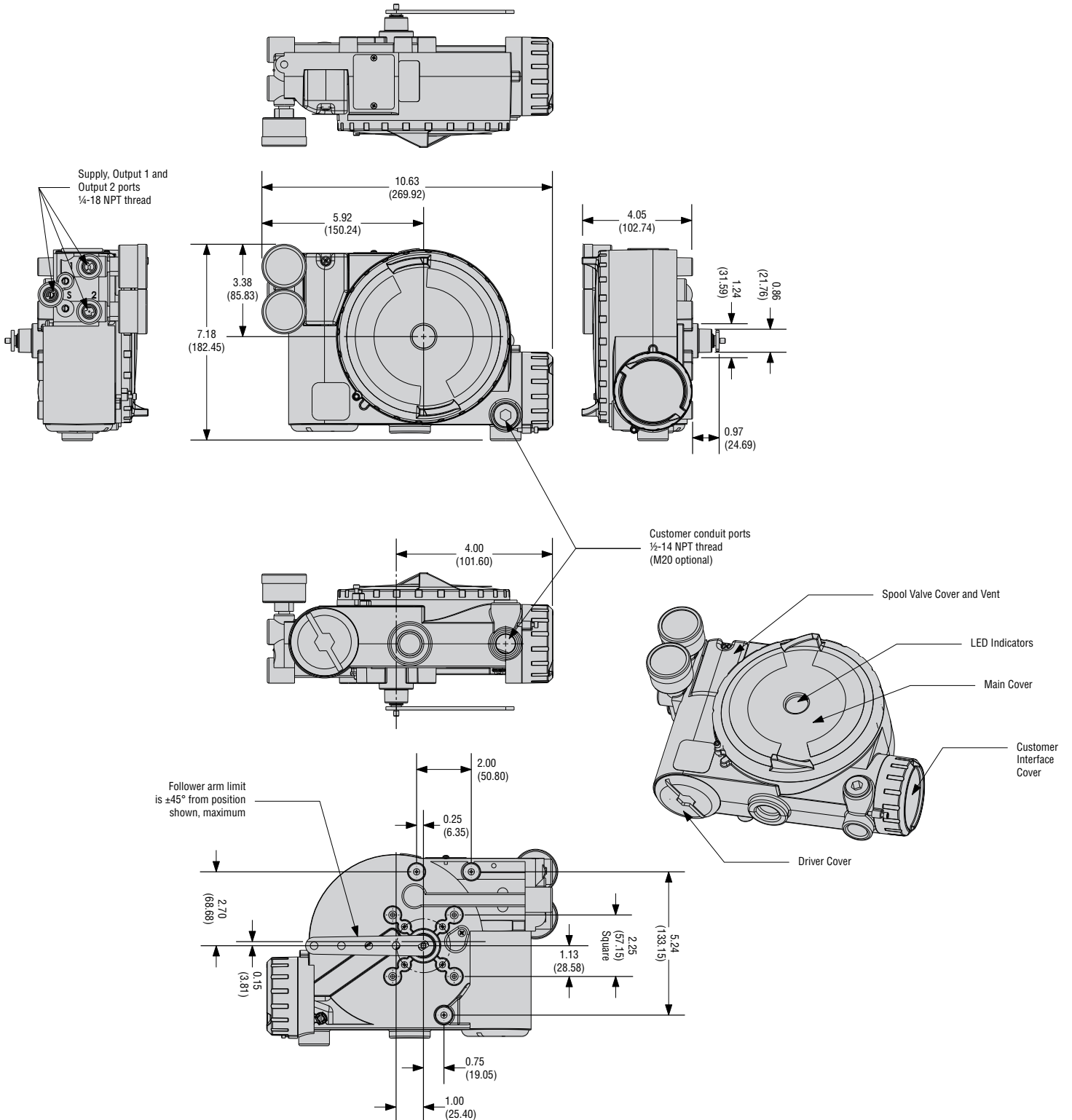

How to order

Selection		Code	Example
		3	3
Protocol	HART	2	4
	Foundation Fieldbus	4	
Diagnostics	Standard (No Sensors)	0	1
	Advanced (With Sensors)	1	
	Pro Diagnostics (with sensors and full ValveSight diagnostics)	2	
Material	Aluminum, White Paint (Valtek)	0	0
	Stainless Steel, No Paint (Valtek)	1	
	Aluminum, Black Paint (Automax)	2	
	Aluminum, Food-Grade White Paint (Automax)	3	
	Aluminum, Black Paint (Accord)	4	
	Aluminum, Food-Grade White Paint (Accord)	5	
Design Version			MD
Certifications	Nonincendive Ex nL nA IIC, ATEX II 3 G, T4amb -40°C to +85°C, T5 Tamb -40°C to +55°C; Intrinsically Safe Ex ia IIC, T4 Tamb -40°C to +85°C, T5 Tamb -40°C to +55°C; Ex ia D 20, T95°C -40°C to +80°C (CENELEC)	04	14
	INMETRO BR-EX ia IIC T4/T5; BR-Ex d IIB+H ₂ , T5 (South America)	06	
	Explosionproof Ex d IIB + H ₂ , Ex tD A21 T95°C, ATEX II 2 G (CENELEC) (GOST GG TN Ex d IIB+H ₂)	07	
	Explosionproof Class I, Div 1, Groups B, C, D Intrinsically Safe Class I, Div 1, Groups A through G (FM, CSA) FM Nonincendive. CSA Class I, Div 2, Class I, Zone 1, Group IIB + H ₂ and Exia Class 1, Zone 0, Group IIC (CSA Only)	10	
	General Purpose	14	
	Intrinsically Safe Ex ia IIC, T4 Tamb -40°C to +85°C, T5 Tamb -40°C to +55°C; Ex ia D 20, T95°C -40°C to +80°C, ATEX II 1 G D (CENELEC) (GOST GG TN Ex i Intrinsically Safe IIC)	15	
	IECEX Explosionproof	16	
	IECEX Intrinsically Safe	21	
Shaft	DD 316 Stainless Steel Shaft (Valtek Standard)	D6	D6
	NAMUR 316 Stainless Steel (VDI/VDE 3845)	N6	
Conduit Connections	½" NPT	E	M
	M20	M	
Action	Four-way (Double-Acting)	04	4V
	Three-way (Single-Acting)	03	
	Four-way Vented (Double-Acting)	4V	
	Three-way Vented (Single-Acting)	3V	
Temperature	Low Temperature (-40°F to 176°F; -40°C to 80°C)	40	40
Gauges	SS with brass internals, psi (bar/kPa) (Valtek Standard)	OG	KS
	SS with SS internals, psi (bar/kPa)	OS	
	SS with brass internals, psi (kg/cm ²)	KG	
	SS with SS internals, psi (kg/cm ²) KS	KS	
	No Gauges	U	
Special Options	No special options	00	OF
	4-20 mA Position Feedback	OF	
	Remote Mount Feedback (Only Available with Certification Option 14)	RM	
	Fail Option Feedback*	SF	

For each category, select the code for one of the options.

* Contact factory before specifying this option

Logix 3400MD Hazardous Area Certifications

Notified Body	Certification Option	Approval	Entity Parameters	Temperature Code	Enclosure Rating		
	-01	Explosionproof: Class I, Div 1, Groups B,C,D Dust Ignition Proof: Class II, III, Div 1, Groups EFG (See Warning No. 1, 2)	Not Applicable	T6 T _{amb} ≤ = 60°C	NEMA 4X		
	-02	Intrinsically Safe: Class I, II, III, Div 1, Groups A,B,C,D Class 1, Zone 0, AEx ia IIC (See Warning No. 2,3)	<table border="1"> <tr> <td>Entity Parameters Ui = 24 Vdc Ii = 250mA Pi = 1.2 W Ci = 3300pF Li = 10µH</td> <td>Fisco Parameters Ui = 17.5 Vdc Ii = 380mA Pi = 5.32W Ci = 3300 pF Li = 10µH</td> </tr> </table> (refer to control drawing No. 234401)	Entity Parameters Ui = 24 Vdc Ii = 250mA Pi = 1.2 W Ci = 3300pF Li = 10µH	Fisco Parameters Ui = 17.5 Vdc Ii = 380mA Pi = 5.32W Ci = 3300 pF Li = 10µH	T4 T _{amb} ≤ = 60°C	NEMA 4X
	Entity Parameters Ui = 24 Vdc Ii = 250mA Pi = 1.2 W Ci = 3300pF Li = 10µH	Fisco Parameters Ui = 17.5 Vdc Ii = 380mA Pi = 5.32W Ci = 3300 pF Li = 10µH					
-02	Non-Incendive: Class I, II, III, Div 2, Groups A,B,C,D (See Warning No. 2)	Install per NEC Article 501-4 when barriers are not used.	T6 T _{amb} -20° to 60° C	NEMA 4X			
	-01	Explosionproof: Class I, Div 1, Groups B,C,D Class II, Div 1, Groups E,F,G Class III Ex d IIB+H2 (See Warning No. 2)	Not Applicable	-20° ≤ Ta ≤ +55°C	Type 4X		
	-07	Explosionproof (Flameproof): II 2 GD Ex d IIB + H ₂ Ex tD A21 T95°C (See Warning No. 1, 2)	Not Required	T5 (T = -40°C to + 80°C)	IP65		
	-04 or -15	Intrinsically Safe: II 1 G Ex ia IIC (See Warning No. 2, 3)	Ui = 30 Volts Ii = 100mA Pi = 800mW Ci = 30 nF Li = 0 Co = 36 nF	T4 (T _{amb} -40°C to + 85°C) T5 (T _{amb} -40°C to + 55°C)	IP65		
	-04	Non-Incendive: II 3 G Ex nL nA IIC (See Warning No. 2)	Not Required	T4 T _{amb} -40°C to + 85°C) T5 T _{amb} -40°C to + 55°C)	IP65		
		Explosionproof (Flameproof): 1Ex d IIBT5/H ₂ X (See Warning No. 1,2)	Not Required	T5 (-50°C ≤ Ta ≤ +55°C)	IP65		
		Intrinsically Safe: 0Ex ia IIC T4X	Ui = 24 Vdc Ii = 250mA Pi = 1.2W Ci = 330 pF Li = 10 µH	T4 (T _{amb} -50°C to + 60°C)	IP65		
IECEX	-21	Intrinsically Safe: Ex ia IIC (See Warning No. 2, 3)	Ui = 24 Vdc Ii = 250mA Pi = 01.2W Ci = 330 pF Li = 10 µH	T4 (T _{amb} -20°C to + 60°C)	IP65		
	-06	Explosionproof (Flameproof): BR-Ex d IIB + H ₂ (See Warning No. 1, 2)	Not Required	T5 (-40°C ≤ Ta ≤ + 55°C)	IP65		
	-06 or -22	Intrinsically Safe: BR- Ex ia IIC (See Warning No. 2, 3)	Ui = 24 Vdc Ii = 250mA Pi = 1.2W Ci = 3300 µF Li = 10 µF	T5 (-40°C ≤ Ta ≤ + 55°C) T4 (-40°C ≤ Ta ≤ + 85°C)	IP65		
GOST R							
GOST K, GOST K GG TN							

WARNINGS:

1. In order to maintain the explosionproof certifications do not remove or loosen covers during operation.
2. To avoid the possibility of static discharge clean only with a damp cloth.
3. The positioner must be connected to suitable rated intrinsically safe equipment, and must be installed in accordance with intrinsically safe installation standards.

Logix 3200MD Hazardous Area Certifications

Notified Body	Certification Option	Approval	Entity Parameters	Temperature Code	Enclosure Rating
	-10	Explosionproof: Class I, Div 1, Groups B,C,D Dust Ignition Proof: Class II, III, Div 1, Groups EFG (See Warning No. 1, 2)	Not Applicable	T6 T _{amb} ≤ 60°C	NEMA 4X
	-10	Intrinsically Safe: Class I, II, III, Div 1, Groups A,B,C,D Class 1, Zone 0, AEx ia IIC (See Warning No. 2,3)	V _{max} = 30 Volts I _{max} = 100mA P _{max} = 800mW C _i = 30 nF L _i = 0 (refer to control drawing No. 198736)	T4 T _{amb} ≤ 85°C T5 T _{amb} ≤ 55°C	NEMA 4X
	-10	Non-Incendive: Class I, Div 2, Groups A,B,C,D (See Warning No. 2)	Install per NEC Article 501-4 when barriers are not used.	T4 T _{amb} ≤ 85°C T5 T _{amb} ≤ 55°C	NEMA 4X
	-10	Explosionproof: Class I, Div 1, Groups B,C,D Class II, Div 1, Groups E,F,G Class III (See Warning No. 1, 2)	Not Applicable	-25° ≤ Ta ≤ +40°C	Type 4X
	10	Intrinsically Safe: Class I, II, III, Div 1, Groups A,B,C,D (See Warning No. 2, 3)	V _{max} = 30 Volts I _{max} = 100mA P _{max} = 800mW C _i = 30 nF L _i = 0 (refer to control drawing No. 198736)	T4 T _{amb} ≤ 80°C	Type 4X
	10	Non-Incendive: Class I, II, Div 2, Groups A,B,C,D (See Warning No. 2)	Not Required	T4 T _{amb} ≤ 80°C	Type 4X
	-07	Explosionproof (Flameproof): II 2 GD Ex d IIB + H ₂ Ex tD A21 T95°C (See Warning No. 1, 2)	Not Required	T5 (T = -40°C to + 80°C)	IP65
	-04 or -15	Intrinsically Safe: II 1 G Ex ia IIC Ex iaD 20 T95°C (See Warning No. 2, 3)	U _i = 30 Volts I _i = 100mA P _i = 800mW C _i = 30 nF L _i = 0 C _o = 36 nF	T4 (T _{amb} -40°C to + 85°C) T5 (T _{amb} -40°C to + 55°C) T99°C (40°C to + 80°C)	IP65
	-04	Non-Incendive: II 3 G Ex nL nA IIC (See Warning No. 2)	Not Required	T4 T _{amb} (-40°C to + 85°C) T5 T _{amb} (-40°C to + 55°C)	IP65
IECEX	-16	Explosionproof (Flameproof): Ex d IIB + H ₂ (See Warning No. 1, 2)	Not Required	T5 (T _{amb} -20°C to + 55°C) T5 (T _{amb} -40°C to + 80°C)	IP65
	-21	Intrinsically Safe: Ex ia IIC (See Warning No. 2, 3)	U _i = 30 Vdc I _i = 100mA P _i = 0.8W C _i = 30 nF L _i = 0	T4 (T _{amb} -40°C to + 85°C)	IP65
		Explosionproof (Flameproof): 1Ex d IIBT5/H ₂ X (See Warning No. 1, 2)	Not Required	T5 (-50°C ≤ Ta ≤ +55°C)	IP65
		Intrinsically Safe: 0Ex ia IICT4X 0Ex ia IICT5X (See Warning No 2,3)	U _i = 30 Volts I _i = 100mA P _i = 800mW C _i = 30 nF L _i = 0	T4 (T _{amb} -50°C to + 60°C)	IP65
	-06	Explosionproof (Flameproof): BR-Ex d IIB + H ₂ (See Warning No. 1, 2)	Not Required	T5 (-40°C ≤ Ta ≤ + 80°C)	IP65
	-06	Intrinsically Safe: BR- Ex ia IIC (See Warning No. 2, 3)	U _i = 30 Vdc I _i = 100mA P _i = 800mW C _i = 30 nF L _i = 0 C _o = 36 nF	T5 (-40°C ≤ Ta ≤ + 55°C) T4 (-40°C ≤ Ta ≤ + 85°C)	IP65
KOSHA	-07	Explosionproof (Flameproof) Ex d IIB + H ₂ (See Warning No. 1, 2)	Not Required	T5 (T = -40°C to + 80°C)	IP65



FCD LGENTB0059-00 Printed in USA.

To find your local Flowserve representative:

For more information about Flowserve Corporation, visit
www.flowserve.com or call USA 1 800 225 6989

Flowserve Headquarters

5215 N. O'Connor Blvd., Suite
2300
Irving, TX 75039
Telephone: 972 443 6500

Control Valve Manufacturing

1350 Mountain Springs Parkway
Springville, UT 84663-3004 USA
Telephone: 1 801 489 8611
Fax: 1 801 489 3719

Singapore

12 Tuas Ave. 20, 638824
Republic of Singapore
Telephone: +65 862 3332
Fax: +65 862 4940

Austria

Kasernengasse 6
Villach Austria 9500
Telephone: +43 0 4242 41181 0
Fax: +43 0 4242 41181 50

Australia

14 Dalmore Dr.
Scoresby, Victoria, Australia 3179
Telephone: +61 3 9759 3300
Fax: +61 3 9759 3301

China

585, Hanwei Plaza
7 Guanghua Road
Beijing, China 100004
Telephone: +86 10 6561 1900

Flowserve Corporation has established industry leadership in the design and manufacture of its products. When properly selected, this Flowserve product is designed to perform its intended function safely during its useful life. However, the purchaser or user of Flowserve products should be aware that Flowserve products might be used in numerous applications under a wide variety of industrial service conditions. Although Flowserve can (and often does) provide general guidelines, it cannot provide specific data and warnings for all possible applications. The purchaser/user must therefore assume the ultimate responsibility for the proper sizing and selection, installation, operation, and maintenance of Flowserve products. The purchaser/user should read and understand the Installation Operation Maintenance (IOM) instructions included with the product, and train its employees and contractors in the safe use of Flowserve products in connection with the specific application.

While the information and specifications contained in this literature are believed to be accurate, they are supplied for informative purposes only and should not be considered certified or as a guarantee of satisfactory results by reliance thereon. Nothing contained herein is to be construed as a warranty or guarantee, express or implied, regarding any matter with respect to this product. Because Flowserve is continually improving and upgrading its product design, the specifications, dimensions and information contained herein are subject to change without notice. Should any question arise concerning these provisions, the purchaser/user should contact Flowserve Corporation at any one of its worldwide operations or offices.

© 2006 Flowserve Corporation, Irving, Texas, USA. Flowserve is a registered trademark of Flowserve Corporation.